

SPD for Photovoltaic System



- Photovoltaic Inverter
- Distribution Power Unit (DPU)
- DC Lightning Protection Box
- DC Power Supply
- Energy Storage Converter
- DC Junction Box

Glossary



Item	Description
U_{cpv}	<p>Maximum Continuous Operating Voltage for PV application Maximum DC voltage, which may be continuously applied to the SPD's mode of protection. — (IEC 61643-31)</p>
8/20 μ s	<p>8/20 Current Impulse Current impulse with a nominal virtual front time of 8 μs and a nominal time to half-value of 20 μs. — (IEC 61643-31)</p>
1.2/50 μ s	<p>1.2/50 Voltage Impulse Voltage impulse with a nominal virtual front time of 1.2 μs and a nominal time to half-value of 50 μs. — (IEC 61643-31)</p>
I_{imp}	<p>Impulse Discharge Current for Class I Test Crest value of a discharge current through the SPD with specified charge transfer Q and specified energy W/R in the specified time. — (IEC 61643-31)</p>
I_n	<p>Nominal Discharge Current Crest value of the current through the SPD having a current waveshape of 8/20. — (IEC 61643-31)</p>
I_{max}	<p>Maximum Discharge Current Crest value of a current through the SPD having an 8/20 waveshape and magnitude according to the manufacturer's specification. I_{max} is equal to or greater than I_n. — (IEC 61643-31)</p>
U_p	<p>Voltage Protection Level Maximum voltage to be expected at the SPD terminals due to an impulse stress with defined voltage steepness and an impulse stress with a discharge current with given amplitude and waveshape. — (IEC 61643-31)</p>
Modes of Protection	<p>Modes of Protection An intended current path, between terminals that contains protective components, for which the manufacturer declares a protection level. — (IEC 61643-31)</p>
IP	<p>Degrees of Protection Provided Classification preceded by the symbol IP indicating the extent of protection provided by an enclosure against access to hazardous parts, against ingress of solid foreign objects and possibly harmful ingress of water. — (IEC 61643-31)</p>

型号说明 Part Numbering System

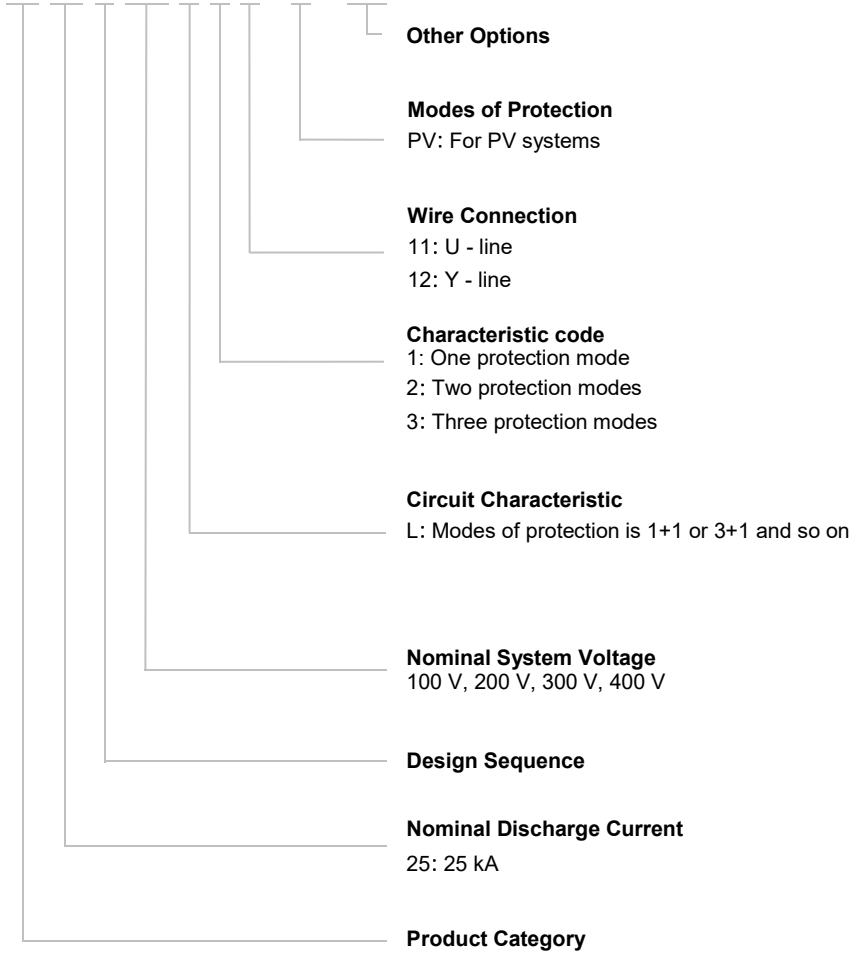
SD 25 T 100 L 2 11 PV -xxx



Agency Information

Agency Information		Standards	NO.	Category
	UL	UL 1449 4th Edition	E322662	VZCA2
	CUL	CSA C22.2 NO.269, CSA ECN 516	E322662	VZCA8
	TUV	IEC/EN 61643-11, IEC/EN 61643-31	See the different models for details	



ATTENTION

Usage

1. The voltage applied continuously to the SPD must not exceed its maximum continuous operating voltage U_c .
2. When atmosphere press is from 45 kPa to 106 kPa, the related altitude shall be from 5000 m to - 500 m.
3. Do not touch the product body or wires directly when power is on, to avoid electric shock.

Replacement

As SPD is a non-repairable product, for safety sake, please use the same type of SPD for replacement.

Storage

Do not store SPD at high temperature, high humidity or corrosive gas environment, to avoid oxidation of the wires. Use them up within 2 years after receiving the goods.

Installation

1. Installation and startup may only be carried out by qualified personnel. The relevant country-specific regulations must be observed.
2. Check the device for external damage before installation. If the device is defective, it must not be used.
3. Pay attention to risk of electric shock. Please cutoff all electrical power before installation or service.
4. Lay the output cables to the surge protective devices (SPDs) as short as possible, without loops.
5. Do not apply mechanical stress to the SPD body during or after the installation.

Maintenance

1. Check SPD status according to instructions before and after the thunderstorm season each year.
2. If the indicator of "failure state" appears, the SPD is damaged. Replace the SPD with same type.
3. Ensure electrical connections and mountings are correct before energizing the circuit.
4. SPD`s quality is well controlled and strictly inspected before delivery. If non-functional ones are found during operation, please contact us early enough.

Wiring Diagram

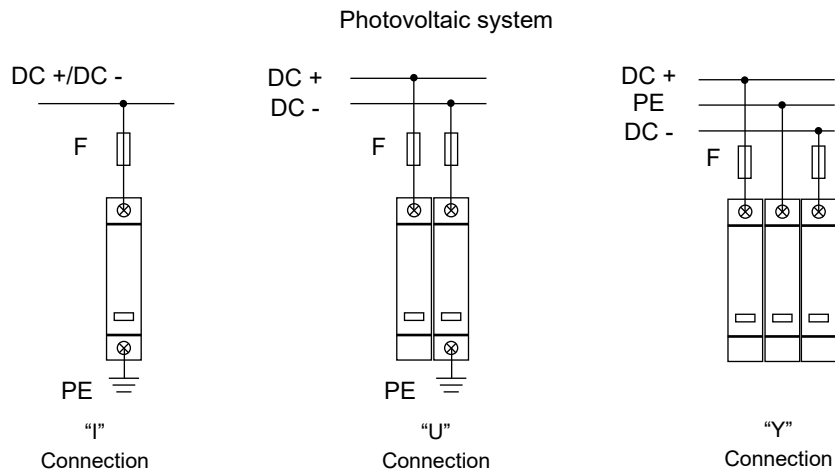

Specifications

Features	Specifications
Degrees of Protection Provided	IP20
Wiring Ability	(1.5 to 25) mm ² (Flexible) / 35 mm ² (Rigid)
Installation	35 mm DIN rail
Alarm	Remote + Indicator
Operating State / Fault Indication	Green / Red
Remote Indication Contacts	AC: 250 V / 0.5 A , 125 V / 1.0 A DC: 250 V / 0.1 A , 125 V / 0.2 A , 75 V / 0.5 A
Cross-section of Remote Indication Conductors	1.5 mm ²
Short Current Rating I_{SCCR}	1000 A
According to Standard	UL 1449, EN 61643-31
Altitude	0 ~ 5000 m
Operational Temperature Range	(-40 to 85) °C



Schematics

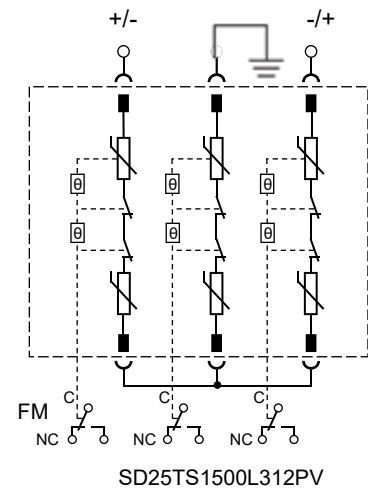
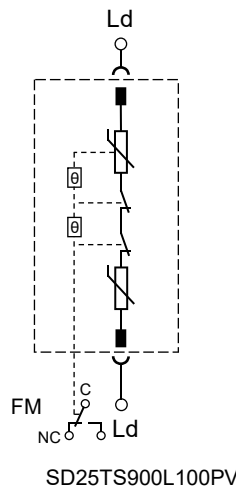

- For DC / PVDC System
- Class I and Class II SPD
- Over-temperature Protection, Overcurrent Protection, High Reliability
- Comply with IEC 61643-31 and UL 1449

Dimensions (mm)

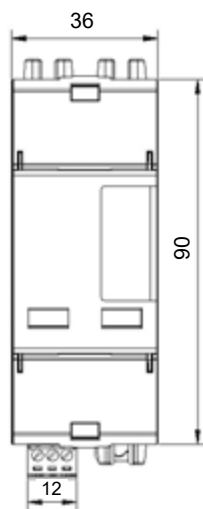

SD25TS900L100PV

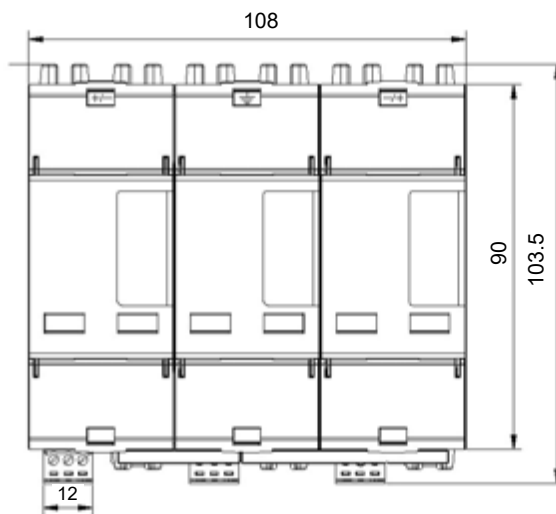

SD25TS1500L312PV

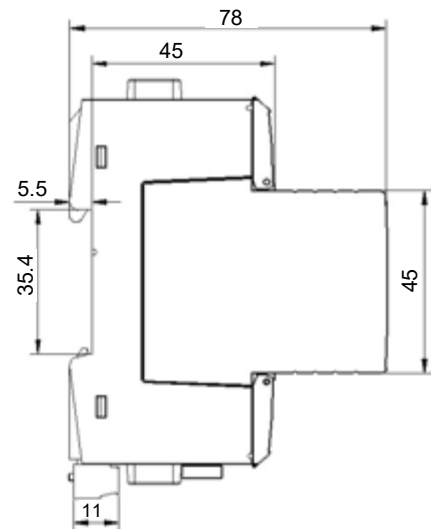

Specifications

Model	Nominal System Voltage (U_n)	Max. Continuous Operating Voltage for PV application (U_{cpv})	Impulse Discharge Current (10/350 μ s) (I_{imp})	Nominal Discharge Current (8/20 μ s) (I_n)	Max. Discharge Current (8/20 μ s) (I_{max})	Voltage Protection Level (U_p)	Modes of Protection	SPD Type
SD25TS900L100PV	900 VDC	900 VDC	12.5 kA	25 kA	50 kA	3.2 kV	1P (Ld - Ld)	T1+T2
SD25TS1500L312P	1500 VDC	1500 VDC	12.5 kA	25 kA	50 kA	6.4 kV	Y	