

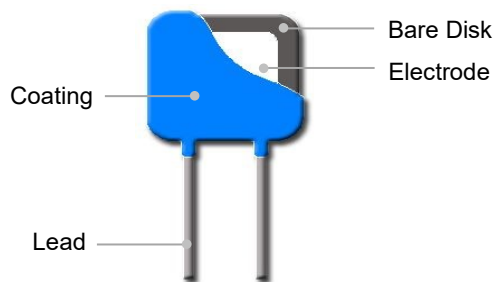

Description

Compared with standard type varistor, the high-surge impact varistor uses materials with extra high performance, having impulse capacity about 30% higher than normal varistor of the same size. Besides, the varistor has good long-term stability, and can be used in higher surge requirement or miniaturization designmen .

Product Structure



Agency Approvals

Agency	Standards	No.
	UL 1449 4 th Edition	on request
	CSA C22.2 NO.269.5-17	on request
	EN 61051-1:2008 IEC 61051-1:2007 IEC 61051-2:1991+A1 IEC 61051-2-2:1991 Annex Q of IEC 60950-1:2005+A1+A2	on request

Features

- High surge tolerance
- High energy quantity
- Customized dimensions are available
- RoHS & REACH Compliant

Lead Types

Lead Types	Codes
	A

Applications

- Power Supplies
- Home Electrical Appliances
- Industrial Devices
- Surge Protectors
- Telecom Devices

Marking

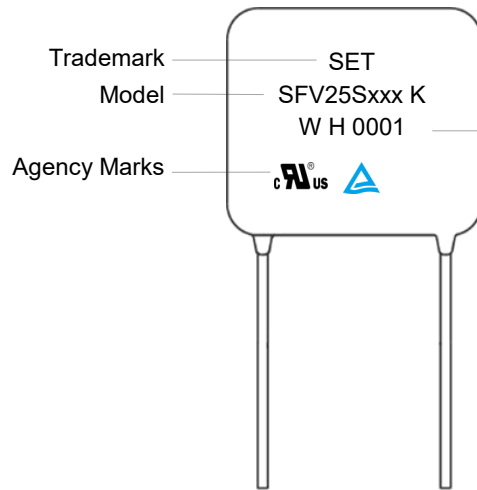

Internal code	
Year Code	2000—A

	2022—W
Surge Level	H: High Energy Type
Serial No.	(E.G.: 0001)

Temp. Derating Curve

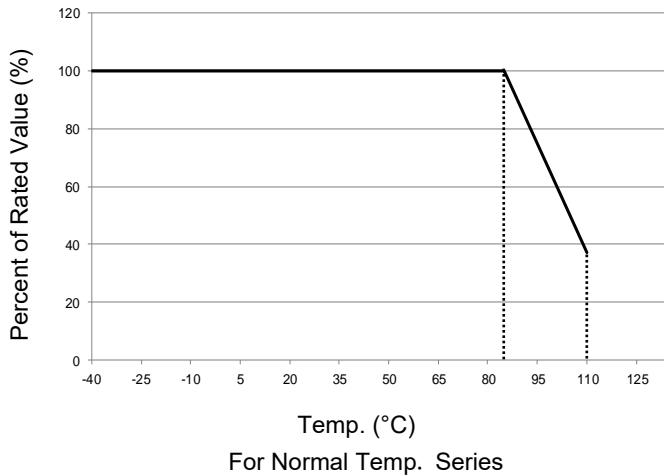

Note: When ambient temp. exceeds 85 °C, the peak surge current and energy rating should be reduced as shown in left curve.

General Technical Data

Item	Value	Unit
Operating Temperature	-40 ~ +85	°C
Storage Temperature	-40 to +125	°C
Voltage Proof	≥2500	V _{ac}
Insulation Resistance	≥100	MΩ

Part Numbering System

SFV 25 S 621 K N xxxxx H - 001

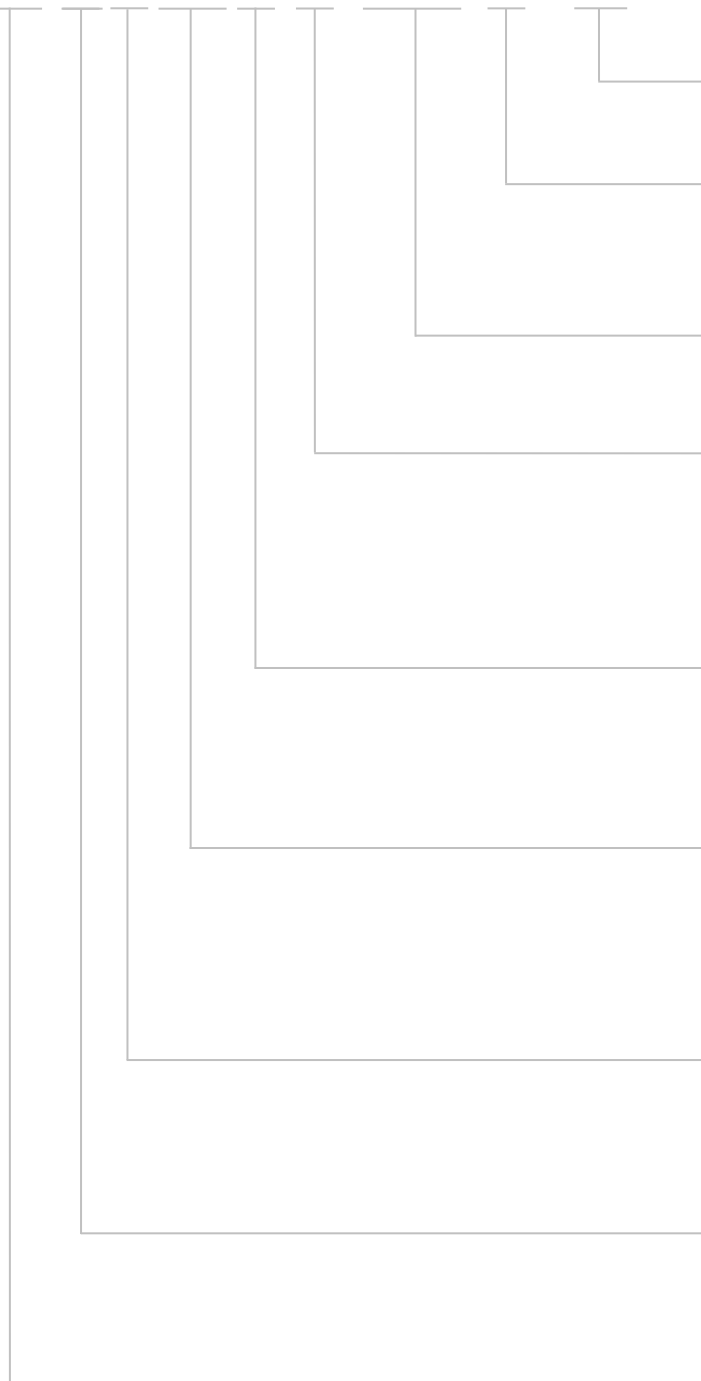

Other Options
001~ZZZ

Performance Code
H: High Surge (8/20 μs)

Structure Code

Coating & Operating Temp.
N: Epoxy Coating 85 °C

Voltage Tolerance
K: ±10%

Nominal Varistor Voltage
820: $82 \times 10^0 = 82V$
621: $62 \times 10^1 = 620 V$
122: $12 \times 10^2 = 1200 V$

Chip Shape
S: Square

Bare Disk Dimension
S 25: 22×25mm

Product Category
Setfuse Varistor

MOV

MOV

*For More Details Refer To Packaging Information.

Glossary

Item	Description
V_N	Nominal Varistor Voltage Voltage, at specified D.C. current used as a reference point in the component characteristics.
I_L	Leakage Current Measuring at 75% of varistor voltage.
UCT	Upper Category Temp. Max. ambient temp. for which a varistor has been designed to operate continuously.
LCT	Lower Category Temp. Minimum ambient temp. at which a varistor has been designed to operate continuously.
Max. Peak Current	Max. Peak Current Max. current per pulse, which may be passed by a varistor at an ambient temp. of 25 °C, for a given number of pulses.
V_C	Clamping Voltage Peak voltage developed across the varistor terminations under standard atmospheric conditions, when passing an 8/20 μs class current pulse.
Voltage Proof	Voltage Proof Max. peak voltage, which may be applied under continuous operating conditions between the varistor terminations and any conducting mounting surface (Applicable only to insulated varistors).
C_V	Capacitance Capacitance across the MOV measured at a specified frequency and voltage.
V_{ac}	Max. Continuous a.c. Voltage Max. a.c. r.m.s. voltage of a substantially sinusoidal waveform (less than 5% total harmonic distortion) which can be applied to the component under continuous operating conditions at 25 °C.
V_{dc}	Max. Continuous d.c. Voltage Max. d.c. voltage (with less than 5% ripple) which can be applied to the component under continuous operating conditions at an ambient temp. of 25 °C.

Dimensions (mm)

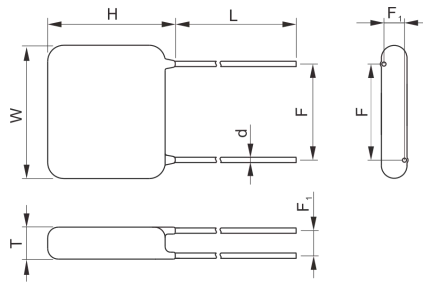





Straight Lead

Model	L	W (Max.)	H (Max.)	T (Max.)	d	F	F ₁
SFV25S241K	16.0±3.0	28	30	7.0	1.20±0.05	18.0±1.0	2.6 - 4.6
SFV25S271K	16.0±3.0	28	30	7.2	1.20±0.05	18.0±1.0	2.8 - 4.8
SFV25S301K	16.0±3.0	28	30	7.4	1.20±0.05	18.0±1.0	3.0 - 5.0
SFV25S331K	16.0±3.0	28	30	7.6	1.20±0.05	18.0±1.0	3.1 - 5.1
SFV25S361K	16.0±3.0	28	30	7.8	1.20±0.05	18.0±1.0	3.3 - 5.3
SFV25S391K	16.0±3.0	28	30	8.0	1.20±0.05	18.0±1.0	3.5 - 5.5
SFV25S431K	16.0±3.0	28	30	8.2	1.20±0.05	18.0±1.0	3.7 - 5.7
SFV25S471K	16.0±3.0	28	30	8.5	1.20±0.05	18.0±1.0	4.0 - 6.0
SFV25S511K	16.0±3.0	28	30	8.7	1.20±0.05	18.0±1.0	4.2 - 6.2
SFV25S561K	16.0±3.0	28	30	9.0	1.20±0.05	18.0±1.0	4.5 - 6.5
SFV25S621K	16.0±3.0	28	30	9.4	1.20±0.05	18.0±1.0	4.8 - 6.8
SFV25S681K	16.0±3.0	28	30	9.8	1.20±0.05	18.0±1.0	5.2 - 7.2
SFV25S751K	16.0±3.0	28	30	10.2	1.20±0.05	18.0±1.0	5.6 - 7.6
SFV25S821K	16.0±3.0	28	30	10.7	1.20±0.05	18.0±1.0	6.0 - 8.0
SFV25S911K	16.0±3.0	28	30	11.2	1.20±0.05	18.0±1.0	6.6 - 8.6
SFV25S102K	16.0±3.0	28	30	11.8	1.20±0.05	18.0±1.0	7.1 - 9.1
SFV25S112K	16.0±3.0	28	30	12.4	1.20±0.05	18.0±1.0	7.7 - 9.7
SFV25S122K	16.0±3.0	28	30	13.0	1.20±0.05	18.0±1.0	8.3 - 10.3

Note:

The above data is for reference only.

Specification

Model	Max. Continuous Operating Voltage		Varistor Voltage @1 mA DC		Clamping Voltage (Max.)		Max. Discharge Current (8/20 μs)		Max. Energy (10/1000 μs)	Typical Capacitance (For reference only) @1 kHz	Agency Approvals			
	VAC	VDC	Min.	Max.	V _C	I _P	I _n	I _{max}	(J)	(pF)				
	(V)	(V)	(V)	(V)	(V)	(A)	(kA)	(kA)			UL	cUL	TUV	CQC
SFV25S241K	150	200	216	264	395	175	12.5	27.5	302	2800	●	●	●	○
SFV25S271K	175	225	243	297	455	175	12.5	27.5	340	2450	●	●	●	○
SFV25S301K	190	250	270	330	500	175	12.5	27.5	375	2200	●	●	●	○
SFV25S331K	210	275	297	363	550	175	12.5	27.5	410	2050	●	●	●	○
SFV25S361K	230	300	324	396	595	175	12.5	27.5	465	1850	●	●	●	○
SFV25S391K	250	320	351	429	650	175	12.5	27.5	520	1700	●	●	●	○
SFV25S431K	275	350	387	473	710	175	12.5	27.5	575	1600	●	●	●	○
SFV25S471K	300	385	423	517	775	175	12.5	27.5	630	1450	●	●	●	○
SFV25S511K	320	415	459	561	845	175	12.5	27.5	665	1300	●	●	●	○
SFV25S561K	350	460	504	616	925	175	12.5	27.5	720	1200	●	●	●	○
SFV25S621K	385	505	558	682	1025	175	12.5	27.5	790	1100	●	●	●	○
SFV25S681K	420	560	612	748	1120	175	12.5	27.5	790	1000	●	●	●	○
SFV25S751K	460	615	675	825	1240	175	12.5	27.5	825	900	●	●	●	○
SFV25S821K	510	670	738	902	1355	175	12.5	27.5	840	800	●	●	●	○
SFV25S911K	550	745	819	1001	1500	175	12.5	27.5	900	700	●	●	●	○
SFV25S102K	625	825	900	1100	1650	175	12.5	27.5	950	660	●	●	●	○
SFV25S112K	680	895	990	1210	1815	175	12.5	27.5	1040	615	●	●	●	○
SFV25S122K	750	1000	1080	1320	1980	175	12.5	27.5	1170	555	●	●	●	○

Note: ● Approved ○ Unauthorized

Soldering Parameters

Wave Soldering Parameters

The wave soldering parameters are for reference only. When MOV is for practice use, some related validation is recommended.

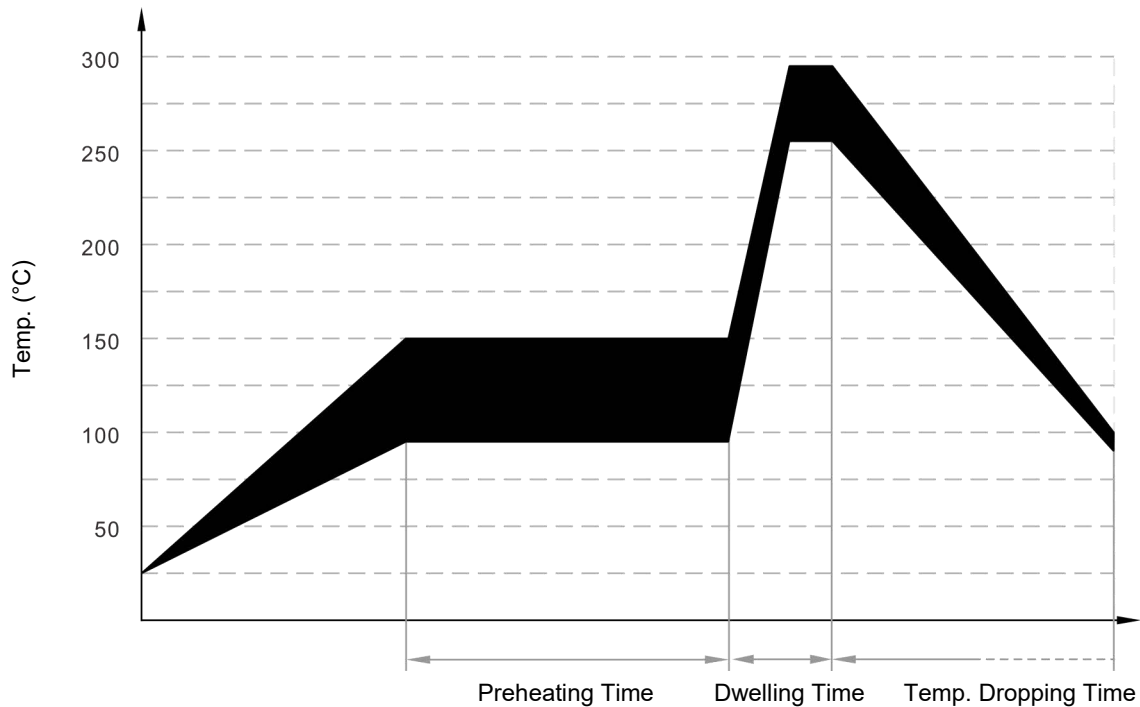

Wave Soldering Curve

Item	Temp. (°C)	Time (s)
Preheating	90 to 150	<150
Dwelling	255 to 290	3 to 10

Recommended Hand-Soldering Parameters

Item	Condition
Temp. of Solder Head	350 °C (max.)
Soldering Time	4 seconds (max.)

Packaging Information

- Bulk Packaging (Code: BUL)
- Bulk Packaging Quantity & Weight.

Series	Nominal Varistor Voltage	PE Bag	Box	Carton	G. W / Carton (365 × 265 × 245)
	(V)	(PCS)	(PCS)	(PCS)	(kg)±10%
25S	241 ~ 821	100	200	1200	15 ~ 26
	911 ~ 122	80	160	960	23 ~ 28

Note:
Other lead length packaging information, please contact SETsafe | SETfuse.

All Dimensions in mm

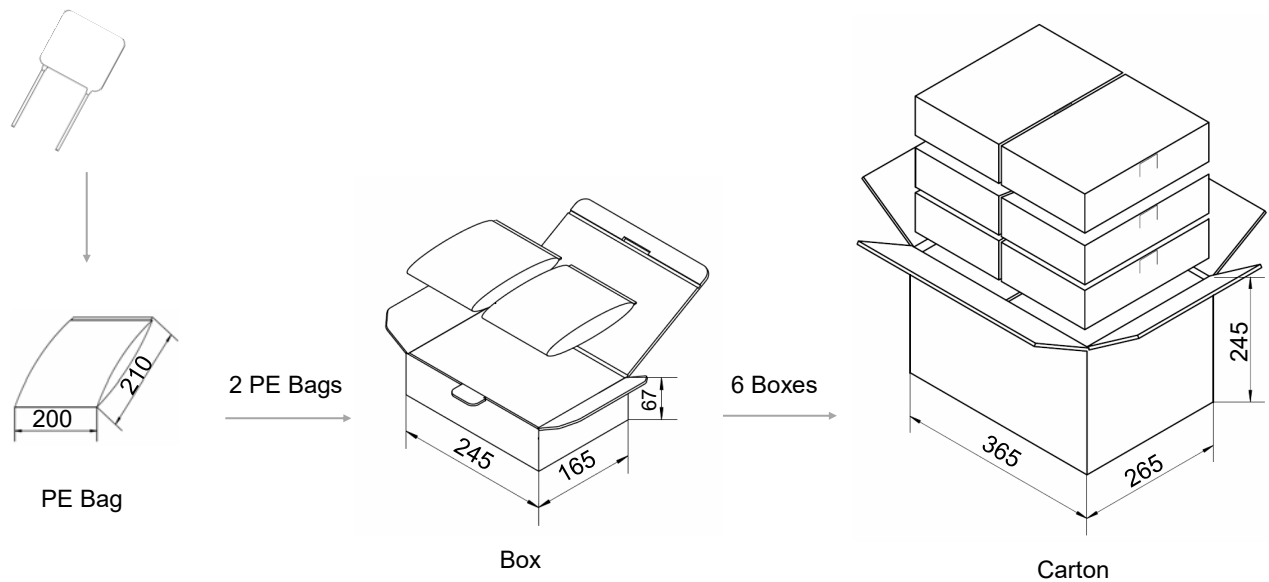



ATTENTION

Usage

1. Varistor must operated in the specified ambient temp.
2. Do not clean the varistor with strong polar solvent such as ketone, esters, benzene and halogenated hydrocarbon.
3. Please do not apply severe vibration, shock or pressure to MOV.
4. Please fix lead wires when bending or cutting. The distance between the bending point and the sealing of MOV shall be greater than 2 mm.

Replacement

If varistor is visually damaged, please replace it.

Storage

1. Storage Temp. Range: (-40 to +125) °C
2. Relative Humidity : ≤75% RH
3. Altitude: <2000 m
4. Do not store the MOV at the high temp., high humidity or corrosive gas environment, to avoid influencing the solder-ability of the lead wires, the product shall be used up within 1 year after receiving the goods.

Environmental Conditions

1. Varistor should neither be exposed to the open air, nor direct sunshine.
2. Varistor should avoid rain, water vapor or other condition of high temp. and high humidity.
3. Varistor should avoid sand dust, salt spray, or other harmful gases.

Max. Typical Capacitance of Varistor

The typical capacitance of varistor is listed in the specifications. Designers may refer to it when designing MOV in high frequency circuit.

Installation

Mechanical Stress

Do not knock MOV when installing, to avoid mechanical damage.