

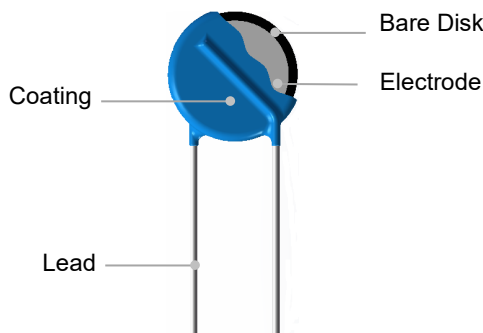

Description

Compared with standard type varistor, the high-surge impact varistor uses materials with extra high performance, having impulse capacity about 30% higher than normal varistor of the same size. Besides, the varistor has good long-term stability, and can be used in higher surge requirement or miniaturization designmen .

Product Structure



Lead Types

| Lead Types | | Codes |
|------------|----------------------|-------|
| | Straight Lead | A |
| | Inward Crimp Lead | B |
| | Outward Crimp Lead | C |
| | Inline Crimp Lead | D |
| | Little Straight Lead | I |

Features

- High surge tolerance
- High energy quantity
- Customized dimensions are available
- RoHS & REACH Compliant

Applications

- Power Supplies
- Home Electrical Appliances
- Industrial Devices
- Surge Protectors
- Telecom Devices

Agency Approvals

| Agency | Standards | No. |
|--------|--|------------|
| | UL 1449 4 th Edition | on request |
| | CSA C22.2 NO.269.5-17 | on request |
| | EN 61051-1:2008 IEC 61051-1:2007 IEC 61051-2:1991 IEC 61051-2-2:1991 Annex G 8.1 of IEC 62368-1:2018 | on request |
| | GB/T 10193-1997 GB/T 10194-1997 GB 4943.1-2011 GB 8898-2011 | on request |

Marking

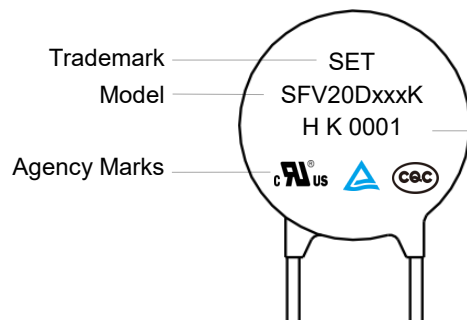

| | |
|---------------|---------------------|
| Internal code | |
| Year Code | 2000—A |
| | |
| | 2022—W |
| Surge Level | H: High Energy Type |
| Serial No. | (E.G.: 0001) |

Temp. Derating Curve

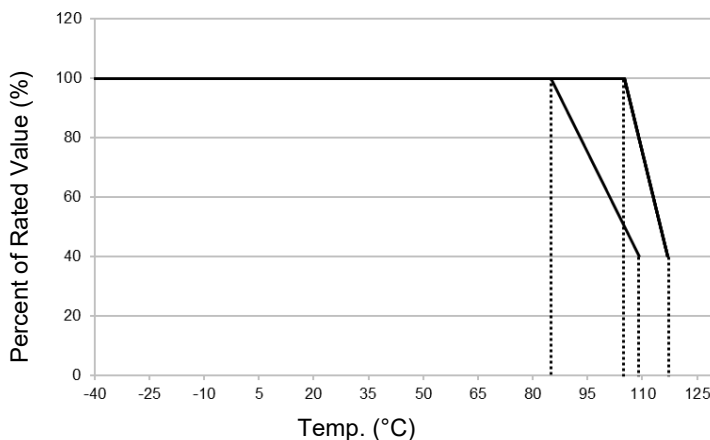

Note: When ambient temp. exceeds 85 °C / 105 °C , the peak surge current and energy rating should be reduced as shown in left curve.

For Normal Temp. Series

General Technical Data

| Item | Value | Unit |
|-----------------------|----------------|-----------------|
| Operating Temperature | -40 ~ +85/+105 | °C |
| Storage Temperature | -40 to +125 | °C |
| Voltage Proof | ≥2500 | V _{ac} |
| Insulation Resistance | ≥100 | MΩ |

Part Numbering System

SFV 20 D 621 K N ××××× H - 001



Other Options
001~ZZZ

Performance Code
H: High Surge (8/20 μs)

Structure Code

Coating & Operating Temp.
N: Epoxy Coating 85 °C
P: Epoxy Coating 105 °C
M: Epoxy Coating 125 °C
T: Silicone Coating 125 °C
B: Bare

Voltage Tolerance
K: ±10%

Nominal Varistor Voltage
820: $82 \times 10^0 = 82V$
621: $62 \times 10^1 = 620 V$
122: $12 \times 10^2 = 1200 V$

Chip Shape
D: Round
S: Square

Bare Disk Dimension
D 20: 20 mm

Product Category
Setfuse Varistor

MOV

MOV

*For More Details Refer To Packaging Information.

Glossary

| Item | Description |
|--------------------------|---|
| V_N | Nominal Varistor Voltage Voltage, at specified D.C. current used as a reference point in the component characteristics. |
| I_L | Leakage Current Measuring at 75% of varistor voltage. |
| UCT | Upper Category Temp. Max. ambient temp. for which a varistor has been designed to operate continuously. |
| LCT | Lower Category Temp. Minimum ambient temp. at which a varistor has been designed to operate continuously. |
| Max. Peak Current | Max. Peak Current Max. current per pulse, which may be passed by a varistor at an ambient temp. of 25 °C, for a given number of pulses. |
| V_C | Clamping Voltage Peak voltage developed across the varistor terminations under standard atmospheric conditions, when passing an 8/20 μs class current pulse. |
| Voltage Proof | Voltage Proof Max. peak voltage, which may be applied under continuous operating conditions between the varistor terminations and any conducting mounting surface (Applicable only to insulated varistors). |
| C_V | Capacitance Capacitance across the MOV measured at a specified frequency and voltage. |
| V_{ac} | Max. Continuous a.c. Voltage Max. a.c. r.m.s. voltage of a substantially sinusoidal waveform (less than 5% total harmonic distortion) which can be applied to the component under continuous operating conditions at 25 °C. |
| V_{dc} | Max. Continuous d.c. Voltage Max. d.c. voltage (with less than 5% ripple) which can be applied to the component under continuous operating conditions at an ambient temp. of 25 °C. |

Dimensions (mm)

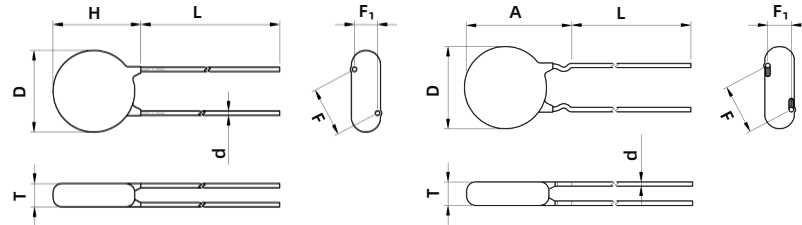

Straight Lead

Inward Crimp

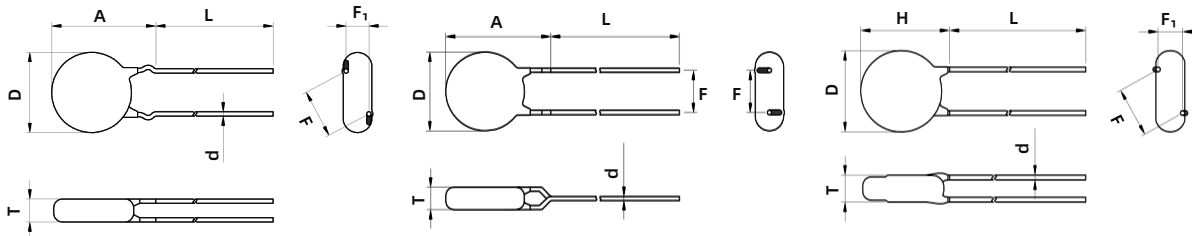

Outward Crimp

Inline Crimp

Little Straight Lead

| Model | L (Min.) | H (Max.) | T (Max.) | D (Max.) | d | F | F ₁ | A (Max.) |
|------------|----------|----------|----------|----------|-----------|----------|----------------|----------|
| SFV20D201K | 20 | 25.5 | 5.1 | 23 | 1.00±0.05 | 10.0±0.6 | 1.5 - 3.2 | 27.5 |
| SFV20D221K | 20 | 25.5 | 5.2 | 23 | 1.00±0.05 | 10.0±0.6 | 1.6 - 3.3 | 27.5 |
| SFV20D241K | 20 | 25.5 | 5.3 | 23 | 1.00±0.05 | 10.0±0.6 | 1.7 - 3.4 | 27.5 |
| SFV20D271K | 20 | 25.5 | 5.5 | 23 | 1.00±0.05 | 10.0±0.6 | 1.8 - 3.6 | 27.5 |
| SFV20D301K | 20 | 25.5 | 5.7 | 23 | 1.00±0.05 | 10.0±0.6 | 1.9 - 3.8 | 27.5 |
| SFV20D331K | 20 | 25.5 | 5.8 | 23 | 1.00±0.05 | 10.0±0.6 | 2.0 - 3.9 | 27.5 |
| SFV20D361K | 20 | 25.5 | 6.0 | 23 | 1.00±0.05 | 10.0±0.6 | 2.1 - 4.1 | 27.5 |
| SFV20D391K | 20 | 25.5 | 6.2 | 23 | 1.00±0.05 | 10.0±0.6 | 2.3 - 4.3 | 27.5 |
| SFV20D431K | 20 | 25.5 | 6.4 | 23 | 1.00±0.05 | 10.0±0.6 | 2.5 - 4.5 | 27.5 |
| SFV20D471K | 20 | 25.5 | 6.7 | 23 | 1.00±0.05 | 10.0±0.6 | 2.8 - 4.8 | 27.5 |
| SFV20D511K | 20 | 25.5 | 6.9 | 23 | 1.00±0.05 | 10.0±0.6 | 3.0 - 5.0 | 27.5 |
| SFV20D561K | 20 | 25.5 | 7.2 | 23 | 1.00±0.05 | 10.0±0.6 | 3.3 - 5.3 | 27.5 |
| SFV20D621K | 20 | 25.5 | 7.6 | 23 | 1.00±0.05 | 10.0±0.6 | 3.6 - 5.6 | 27.5 |
| SFV20D681K | 20 | 25.5 | 8.0 | 23 | 1.00±0.05 | 10.0±0.6 | 4.0 - 6.0 | 27.5 |

Note:

The above data is for reference only.

Specification

| Model | Surge Level | Max. Continuous Operating Voltage | | Varistor Voltage @1 mA DC | | Clamping Voltage (Max.) | | Max. Peak Current (1 time, 8/20 μs) | Max. Energy (8/20 μs) | Typical Capacitance (For reference only) @1 kHz | Agency Approvals | | | |
|------------|-------------|-----------------------------------|-----|---------------------------|------|-------------------------|----------------|-------------------------------------|-----------------------|---|------------------|-----|-----|-----|
| | | Vac | Vdc | Min. | Max. | V _C | I _P | | | | UL | CUL | TUV | CQC |
| | | (V) | (V) | (V) | (V) | (V) | (A) | | | | | | | |
| SFV20D201K | H | 130 | 170 | 180 | 220 | 340 | 100 | 13 | 300 | 2000 | ● | ● | ● | ● |
| SFV20D221K | H | 140 | 180 | 198 | 242 | 360 | 100 | 13 | 320 | 1800 | ● | ● | ● | ● |
| SFV20D241K | H | 150 | 200 | 216 | 264 | 395 | 100 | 13 | 340 | 1650 | ● | ● | ● | ● |
| SFV20D271K | H | 175 | 225 | 243 | 297 | 455 | 100 | 13 | 380 | 1500 | ● | ● | ● | ● |
| SFV20D301K | H | 190 | 250 | 270 | 330 | 500 | 100 | 13 | 400 | 1300 | ● | ● | ● | ● |
| SFV20D331K | H | 210 | 275 | 297 | 363 | 550 | 100 | 13 | 440 | 1200 | ● | ● | ● | ● |
| SFV20D361K | H | 230 | 300 | 324 | 396 | 595 | 100 | 13 | 470 | 1100 | ● | ● | ● | ● |
| SFV20D391K | H | 250 | 320 | 351 | 429 | 650 | 100 | 13 | 510 | 1000 | ● | ● | ● | ● |
| SFV20D431K | H | 275 | 350 | 387 | 473 | 710 | 100 | 13 | 550 | 930 | ● | ● | ● | ● |
| SFV20D471K | H | 300 | 385 | 423 | 517 | 775 | 100 | 13 | 600 | 850 | ● | ● | ● | ● |
| SFV20D511K | H | 320 | 415 | 459 | 561 | 845 | 100 | 13 | 650 | 780 | ● | ● | ● | ● |
| SFV20D561K | H | 350 | 460 | 504 | 616 | 925 | 100 | 13 | 700 | 710 | ● | ● | ● | ● |
| SFV20D621K | H | 385 | 505 | 558 | 682 | 1025 | 100 | 13 | 700 | 650 | ● | ● | ● | ● |
| SFV20D681K | H | 420 | 560 | 612 | 748 | 1120 | 100 | 13 | 800 | 600 | ● | ● | ● | ● |

Note: ● Approved ○ Unauthorized

Soldering Parameters

Wave Soldering Parameters

The wave soldering parameters are for reference only. When MOV is for practice use, some related validation is recommended.

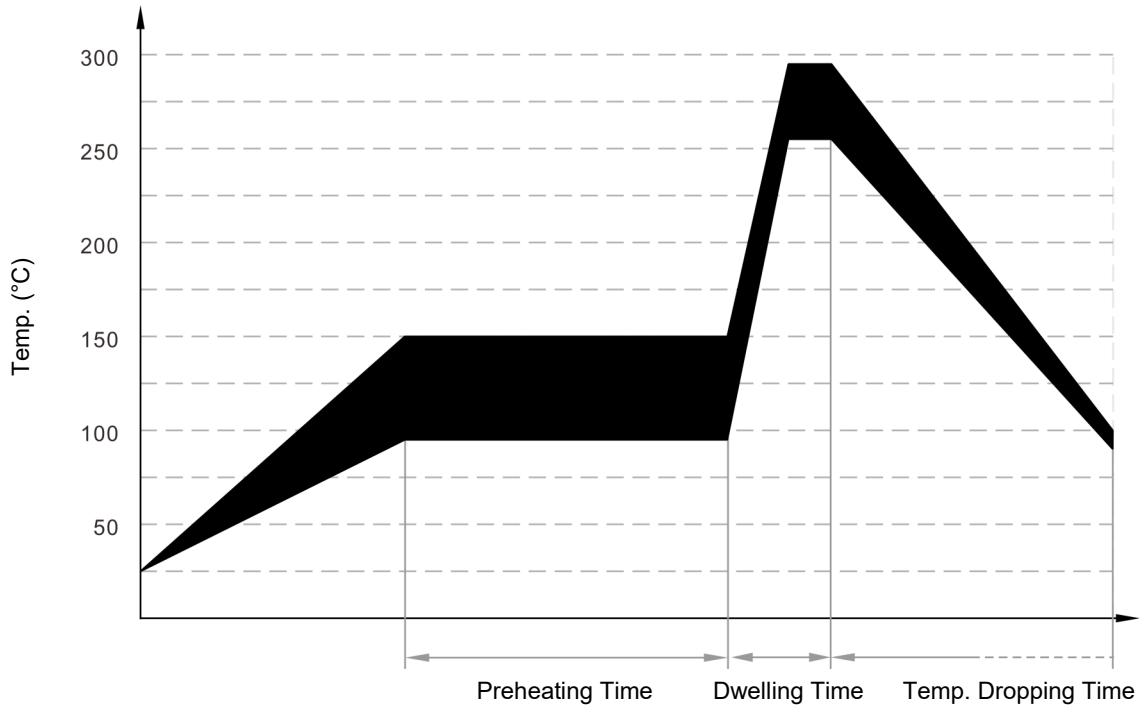

Wave Soldering Curve

| Item | Temp. (°C) | Time (s) |
|------------|------------|----------|
| Preheating | 90 to 150 | <150 |
| Dwelling | 255 to 290 | 3 to 10 |

Recommended Hand-Soldering Parameters

| Item | Condition |
|----------------------|------------------|
| Temp. of Solder Head | 350 °C (max.) |
| Soldering Time | 4 seconds (max.) |

MOV

Metal Oxide Varistor

Packaging Information

- Bulk Packaging (Code: BUL)
- Bulk Packaging Quantity & Weight.

| Series | Nominal Varistor Voltage | PE Bag | Box | Carton | G. W / Carton (365 × 265 × 245) |
|--------|--------------------------|--------|-------|--------|------------------------------------|
| | (V) | (PCS) | (PCS) | (PCS) | (kg)±10% |
| 20D | 201 ~ 471 | 250 | 500 | 3000 | 11 ~ 16 |
| | 511 ~ 681 | 200 | 400 | 2400 | 14 ~ 18 |

Note:

Other lead length packaging information, please contact SETsafe | SETfuse.

All Dimensions in mm

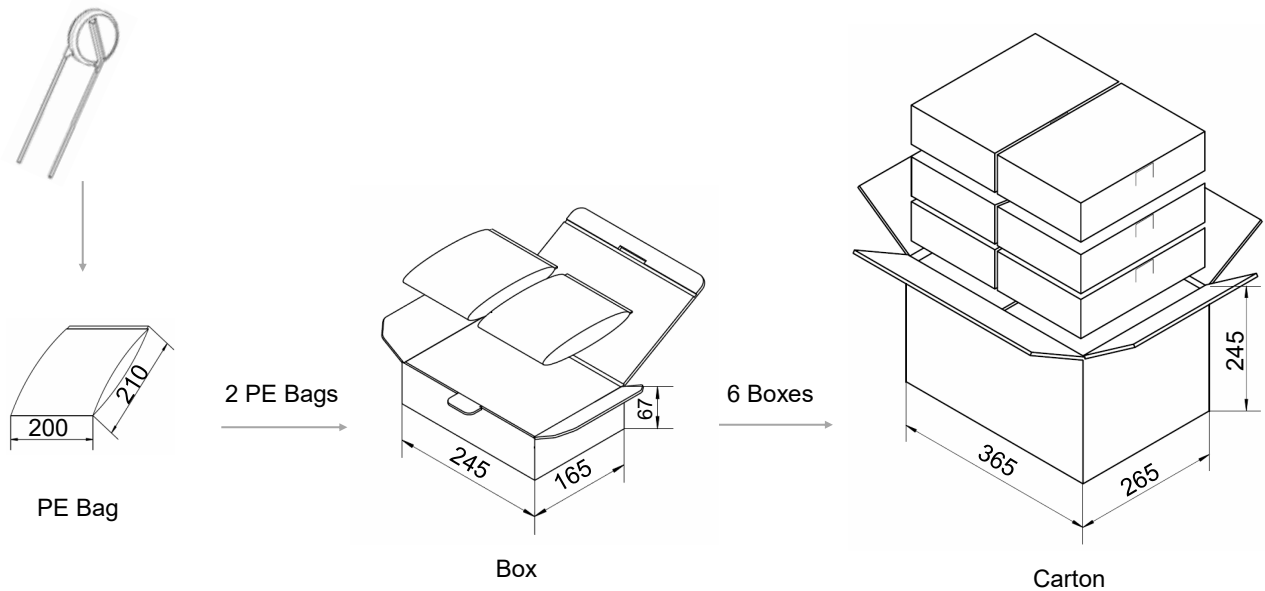

MOV

Metal Oxide Varistor

Packaging Information

- Tape Packaging (Code: 1AB)

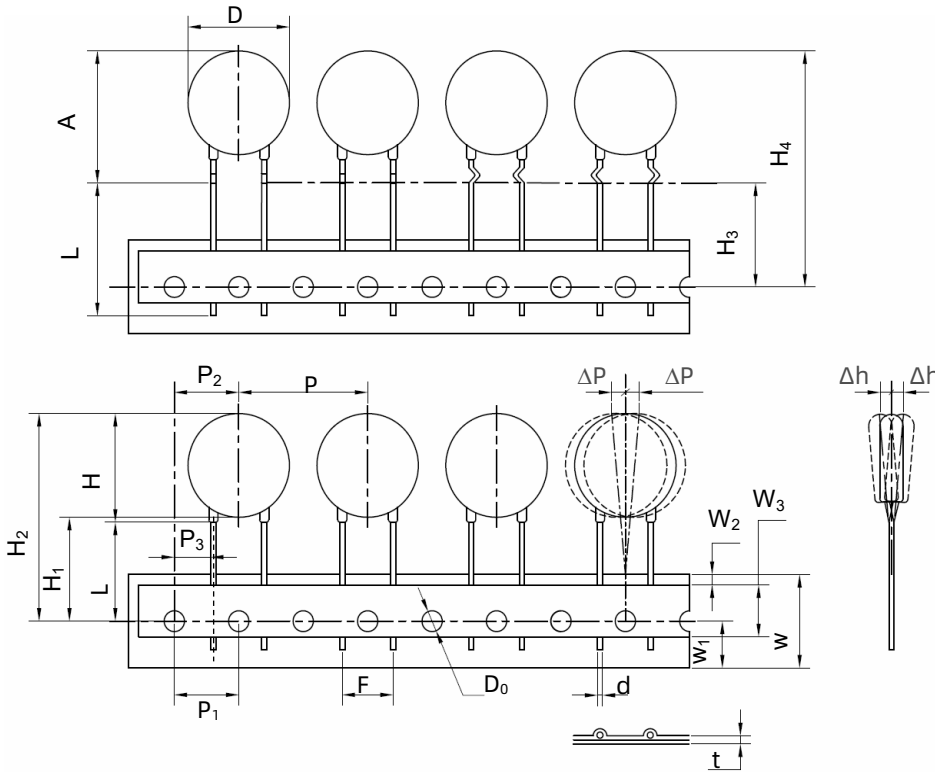

| Dimensions (mm) | |
|-----------------------|------------------------------------|
| Symbol | Dimensions |
| P | 25.4±1.0 |
| P ₁ | 12.7±0.3 |
| P ₂ | 12.7±1.3 |
| P ₃ | 7.7±0.7 |
| ΔP(max.) | 1.0 |
| W | 18.0±1.0 |
| W ₁ | 9.0±1.0 |
| W ₂ (max.) | 3.0 |
| W ₃ | 10.0±2.0 |
| H(max.) | 25.5 |
| H ₁ | 18.0 ^{+2.0} ₋₀ |
| H ₂ (max.) | 45.0 |
| H ₃ | 18.0 ^{+2.0} ₋₀ |
| H ₄ (max.) | 48.0 |
| Δh(max.) | 2.0 |
| t(max.) | 0.6 |
| D(max.) | 23.0 |
| D ₀ | 4.0±0.2 |
| d | 1.00±0.05 |
| A(max.) | 27.5 |
| F | 10.0±1.0 |
| L(min.) | Taping |

- Tape Packaging Quantity & Weight.

| Series | Nominal Varistor Voltage (V) | Box (PCS) | Carton (PCS) | (365 × 265 × 415) G.W. / Carton (kg)±10% |
|--------|------------------------------|-----------|--------------|--|
| 20D | 621 - 681 | 350 | 2100 | 17 - 18 |
| | 471 - 561 | 400 | 2400 | 16 - 17 |
| | 391 - 431 | 450 | 2700 | 15 - 16 |
| | 301 - 361 | 500 | 3000 | 15 - 16 |
| | 221 - 271 | 550 | 3300 | 13 - 15 |
| | 201 | 600 | 3600 | 14 |

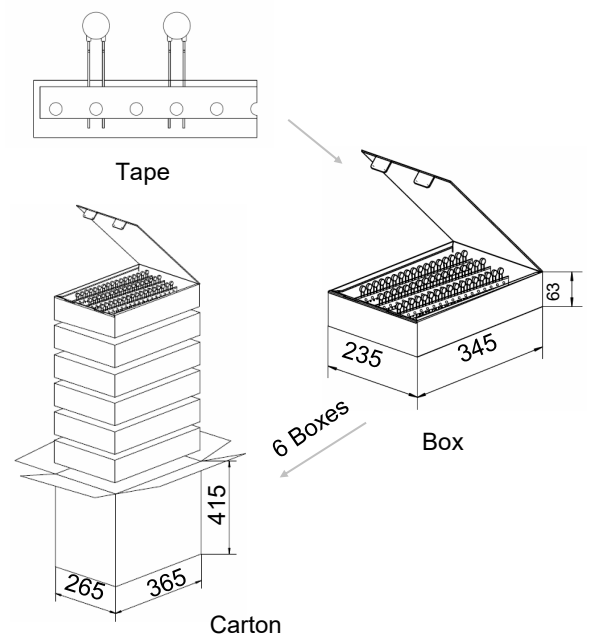

Packaging Information

- Tape Packaging (Code: 1EB)

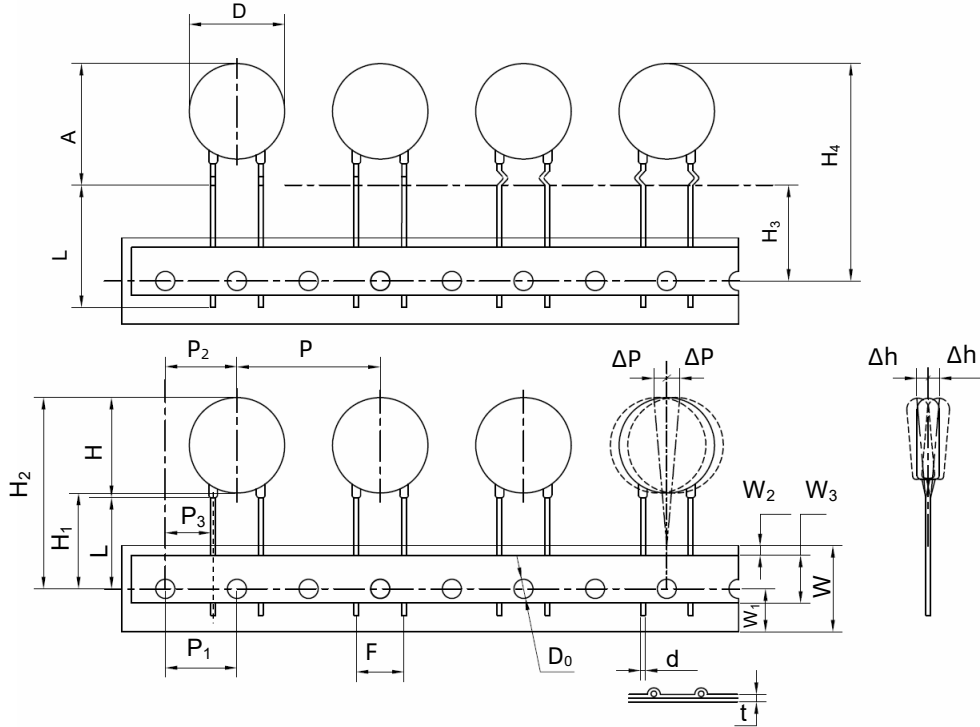

| Dimensions (mm) | |
|-----------------------|------------------------------------|
| Symbol | Dimensions |
| P | 30.0±1.0 |
| P ₁ | 15.0±0.3 |
| P ₂ | 15.0±1.3 |
| P ₃ | 10.0±1.0 |
| ΔP(max.) | 1.0 |
| W | 18.0±1.0 |
| W ₁ | 9.0±1.0 |
| W ₂ (max.) | 3.0 |
| W ₃ | 10.0±2.0 |
| H(max.) | 25.5 |
| H ₁ | 18.0 ^{+2.0} ₋₀ |
| H ₂ (max.) | 45.0 |
| H ₃ | 18.0 ^{+2.0} ₋₀ |
| H ₄ (max.) | 48.0 |
| Δh(max.) | 2.0 |
| t (max.) | 0.6 |
| D(max.) | 23.0 |
| D ₀ | 4.0±0.2 |
| d | 1.00±0.05 |
| A(max.) | 27.5 |
| F | 10.0±0.5 |
| L(min.) | Taping |

- Tape Packaging Quantity & Weight.

| Series | Nominal Varistor Voltage (V) | Box (PCS) | Carton (PCS) | G. W / Carton (365 × 265 × 415) (kg)±10% |
|--------|------------------------------|-----------|--------------|--|
| 20D | 561 - 681 | 300 | 1800 | 13 - 15 |
| | 431 - 511 | 350 | 2100 | 13 - 14 |
| | 331 - 391 | 400 | 2400 | 12 - 14 |
| | 241 - 301 | 450 | 2700 | 11 - 13 |
| | 201 - 221 | 500 | 3000 | 11 - 12 |

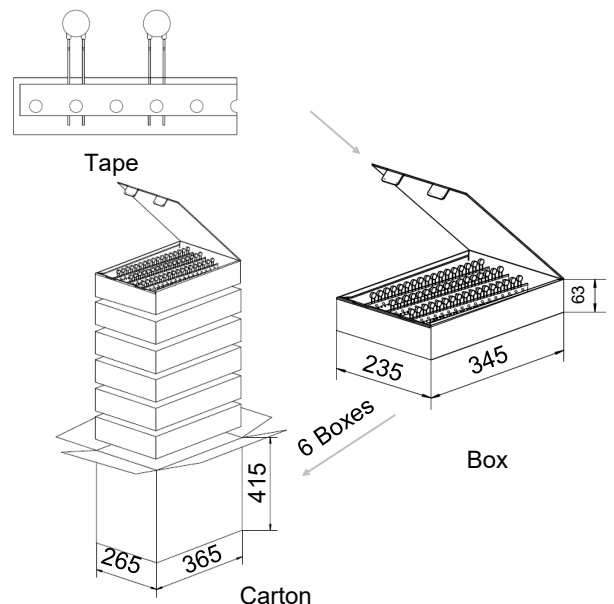



ATTENTION

Usage

1. Varistor must operated in the specified ambient temp.
2. Do not clean the varistor with strong polar solvent such as ketone, esters, benzene and halogenated hydrocarbon.
3. Please do not apply severe vibration, shock or pressure to MOV.
4. Please fix lead wires when bending or cutting. The distance between the bending point and the sealing of MOV shall be greater than 2 mm.

Replacement

If varistor is visually damaged, please replace it.

Storage

1. Storage Temp. Range: (-40 to +125) °C
2. Relative Humidity : ≤75% RH
3. Altitude: <2000 m
4. Do not store the MOV at the high temp., high humidity or corrosive gas environment, to avoid influencing the solder-ability of the lead wires, the product shall be used up within 1 year after receiving the goods.

Environmental Conditions

1. Varistor should neither be exposed to the open air, nor direct sunshine.
2. Varistor should avoid rain, water vapor or other condition of high temp. and high humidity.
3. Varistor should avoid sand dust, salt spray, or other harmful gases.

Max. Typical Capacitance of Varistor

The typical capacitance of varistor is listed in the specifications. Designers may refer to it when designing MOV in high frequency circuit.

Installation

Mechanical Stress

Do not knock MOV when installing, to avoid mechanical damage.