

MOV

Metal Oxide Varistor



Description

Compared with standard type varistor, the high-surge impact varistor uses materials with extra high performance, having impulse capacity about 30% higher than normal varistor of the same size. Besides, the varistor has good long-term stability, and can be used in higher surge requirement or miniaturization designmen .

Product Structure

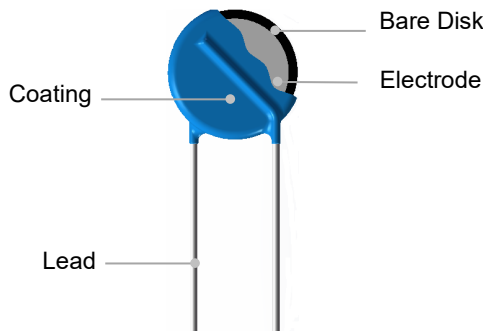

Lead Types

Lead Types		Codes
	Straight Lead	A
	Inward Crimp Lead	B
	Outward Crimp Lead	C
	Inline Crimp Lead	D
	Little Straight Lead	I

Features

- High surge tolerance
- High energy quantity
- Customized dimensions are available
- RoHS & REACH Compliant

Applications

- Power Supplies
- Home Electrical Appliances
- Industrial Devices
- Surge Protectors
- Telecom Devices

Agency Approvals

Agency	Standards	No.
	UL 1449 4 th Edition	on request
	CSA C22.2 NO.269.5-17	on request
	EN 61051-1:2008 IEC 61051-1:2007 IEC 61051-2:1991+A1 IEC 61051-2-2:1991 Annex G.8.1 of IEC 62368-1:2018	on request
	GB/T 10193-1997 GB/T 10194-1997 GB 4943.1-2011 GB 8898-2011	on request

Marking

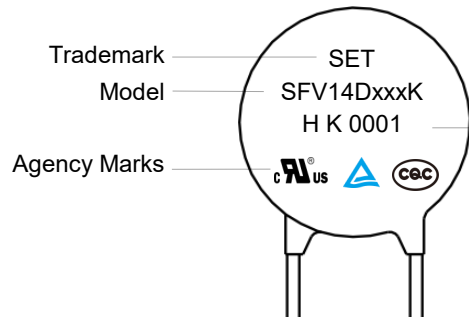

Internal code	
Year Code	2000—A 2022—W
Surge Level	H: High Energy Type
Serial No.	(E.G.: 0001)

Temp. Derating Curve

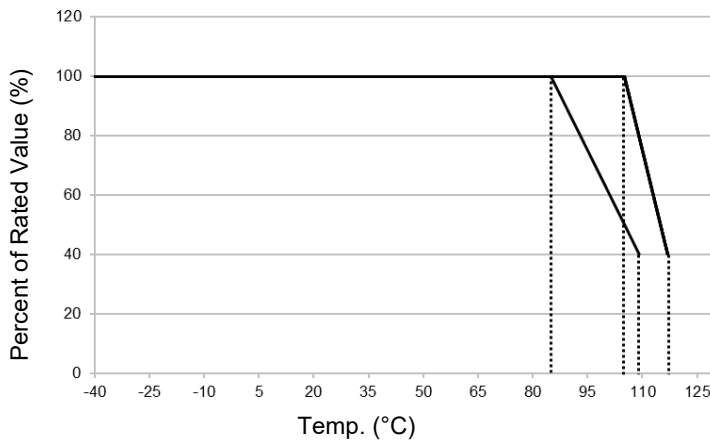

For Normal Temp. Series

Note: When ambient temp. exceeds 85 °C / 105 °C , the peak surge current and energy rating should be reduced as shown in left curve.

General Technical Data

Item	Value	Unit
Operating Temperature	-40 ~ +85/+105	°C
Storage Temperature	-40 to +125	°C
Voltage Proof	≥2500	V _{ac}
Insulation Resistance	≥100	MΩ

Part Numbering System

SFV 14 D 621 K N xxxxx H - 001

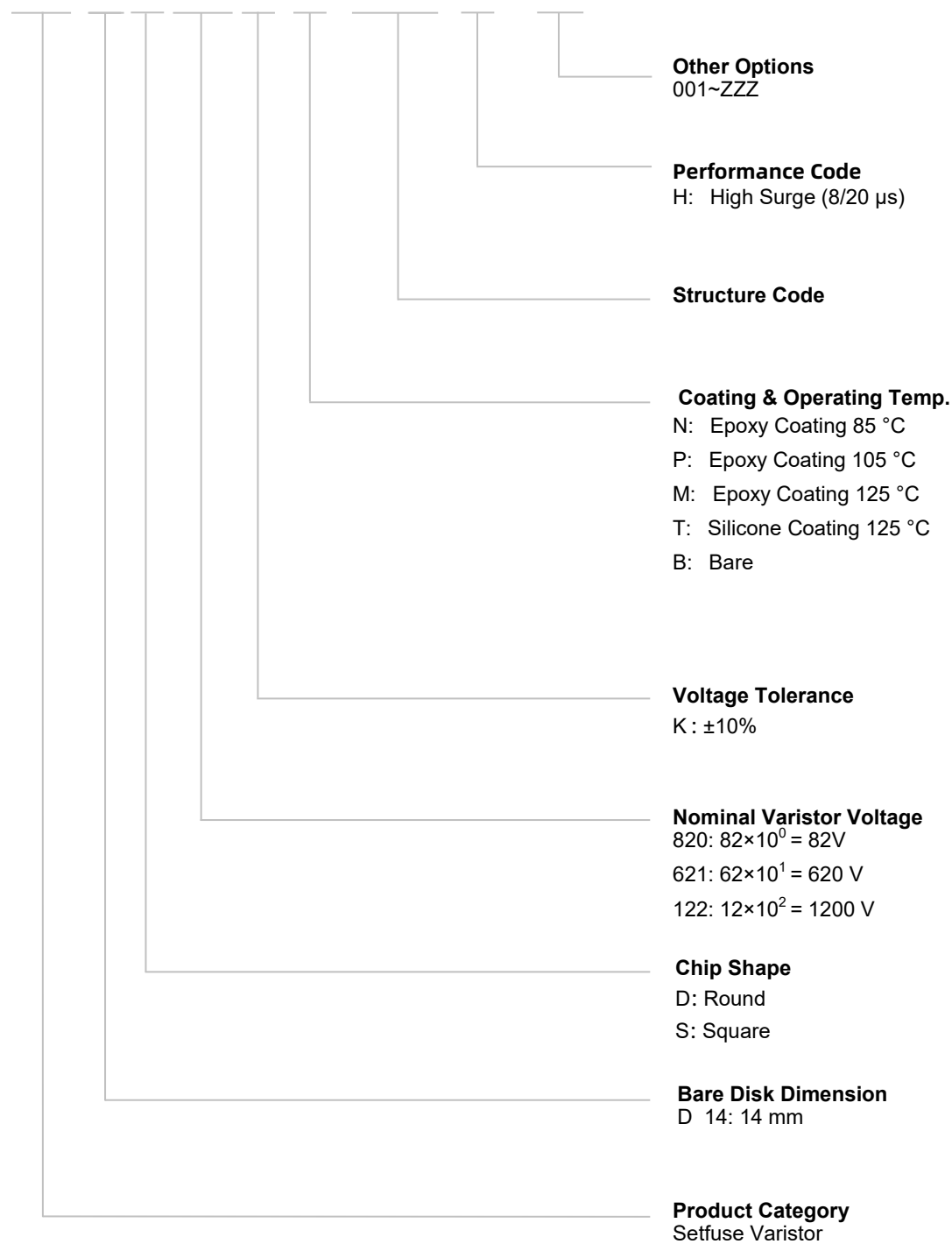

MOV

MOV

*For More Details Refer To Packaging Information.

Glossary

Item	Description
V_N	Nominal Varistor Voltage Voltage, at specified D.C. current used as a reference point in the component characteristics.
I_L	Leakage Current Measuring at 75% of varistor voltage.
UCT	Upper Category Temp. Max. ambient temp. for which a varistor has been designed to operate continuously.
LCT	Lower Category Temp. Minimum ambient temp. at which a varistor has been designed to operate continuously.
Max. Peak Current	Max. Peak Current Max. current per pulse, which may be passed by a varistor at an ambient temp. of 25 °C, for a given number of pulses.
V_C	Clamping Voltage Peak voltage developed across the varistor terminations under standard atmospheric conditions, when passing an 8/20 μs class current pulse.
Voltage Proof	Voltage Proof Max. peak voltage, which may be applied under continuous operating conditions between the varistor terminations and any conducting mounting surface (Applicable only to insulated varistors).
C_V	Capacitance Capacitance across the MOV measured at a specified frequency and voltage.
V_{ac}	Max. Continuous a.c. Voltage Max. a.c. r.m.s. voltage of a substantially sinusoidal waveform (less than 5% total harmonic distortion) which can be applied to the component under continuous operating conditions at 25 °C.
V_{dc}	Max. Continuous d.c. Voltage Max. d.c. voltage (with less than 5% ripple) which can be applied to the component under continuous operating conditions at an ambient temp. of 25 °C.

Dimensions (mm)

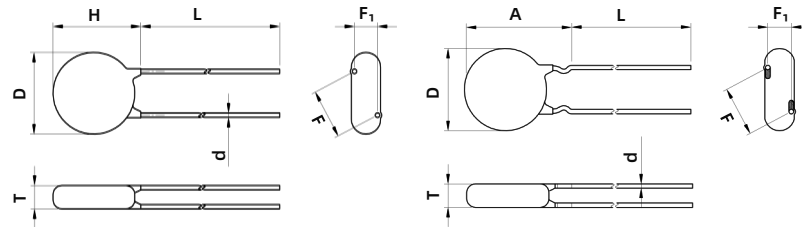

Straight Lead

Inward Crimp

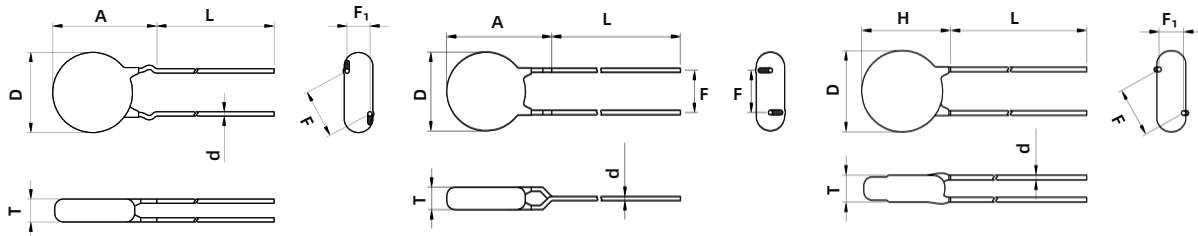

Outward Crimp

Inline Crimp

Little Straight Lead

Model	L (Min.)	H (Max.)	T (Max.)	D (Max.)	d	F	F ₁	A (Max.)
SFV14D201K	20	18.5	4.6	16.5	0.80±0.05	7.5±0.6	1.3 - 2.9	21.5
SFV14D221K	20	18.5	4.7	16.5	0.80±0.05	7.5±0.6	1.4 - 3.0	21.5
SFV14D241K	20	18.5	4.9	16.5	0.80±0.05	7.5±0.6	1.4 - 3.1	21.5
SFV14D271K	20	18.5	5.0	16.5	0.80±0.05	7.5±0.6	1.5 - 3.3	21.5
SFV14D301K	20	18.5	5.2	16.5	0.80±0.05	7.5±0.6	1.7 - 3.5	21.5
SFV14D331K	20	18.5	5.4	16.5	0.80±0.05	7.5±0.6	1.8 - 3.6	21.5
SFV14D361K	20	18.5	5.6	16.5	0.80±0.05	7.5±0.6	1.9 - 3.8	21.5
SFV14D391K	20	18.5	5.7	16.5	0.80±0.05	7.5±0.6	2.0 - 4.0	21.5
SFV14D431K	20	18.5	6.0	16.5	0.80±0.05	7.5±0.6	2.2 - 4.2	21.5
SFV14D471K	20	18.5	6.2	16.5	0.80±0.05	7.5±0.6	2.4 - 4.4	21.5
SFV14D511K	20	18.5	6.4	16.5	0.80±0.05	7.5±0.6	2.6 - 4.6	21.5
SFV14D561K	20	18.5	6.7	16.5	0.80±0.05	7.5±0.6	2.9 - 4.9	21.5
SFV14D621K	20	18.5	7.1	16.5	0.80±0.05	7.5±0.6	3.2 - 5.2	21.5
SFV14D681K	20	18.5	7.4	16.5	0.80±0.05	7.5±0.6	3.6 - 5.6	21.5

Note:

The above data is for reference only.

Specification

Model	Surge Level	Max. Continuous Operating Voltage		Varistor Voltage @1 mA DC		Clamping Voltage (Max.)		Max. Peak Current (1 time, 8/20 μs)	Max. Energy (8/20 μs)	Typical Capacitance (For reference only) @1 kHz	Agency Approvals			
		Vac	Vdc	Min.	Max.	V _C	I _P				UL	CUL	TUV	CQC
		(V)	(V)	(V)	(V)	(V)	(A)							
SFV14D201K	H	130	170	180	220	340	50	8	150	1000	●	●	●	●
SFV14D221K	H	140	180	198	242	360	50	8	160	900	●	●	●	●
SFV14D241K	H	150	200	216	264	395	50	8	180	830	●	●	●	●
SFV14D271K	H	175	225	243	297	455	50	8	200	740	●	●	●	●
SFV14D301K	H	190	250	270	330	500	50	8	220	670	●	●	●	●
SFV14D331K	H	210	275	297	363	550	50	8	245	610	●	●	●	●
SFV14D361K	H	230	300	324	396	595	50	8	260	560	●	●	●	●
SFV14D391K	H	250	320	351	429	650	50	8	290	510	●	●	●	●
SFV14D431K	H	275	350	387	473	710	50	8	320	460	●	●	●	●
SFV14D471K	H	300	385	423	517	775	50	8	350	430	●	●	●	●
SFV14D511K	H	320	415	459	561	845	50	8	380	390	●	●	●	●
SFV14D561K	H	350	460	504	616	925	50	8	400	360	●	●	●	●
SFV14D621K	H	385	505	558	682	1025	50	8	400	320	●	●	●	●
SFV14D681K	H	420	560	612	748	1120	50	8	400	290	●	●	●	●

Note: ● Approved ○ Unauthorized

Soldering Parameters

Wave Soldering Parameters

The wave soldering parameters are for reference only. When MOV is for practice use, some related validation is recommended.

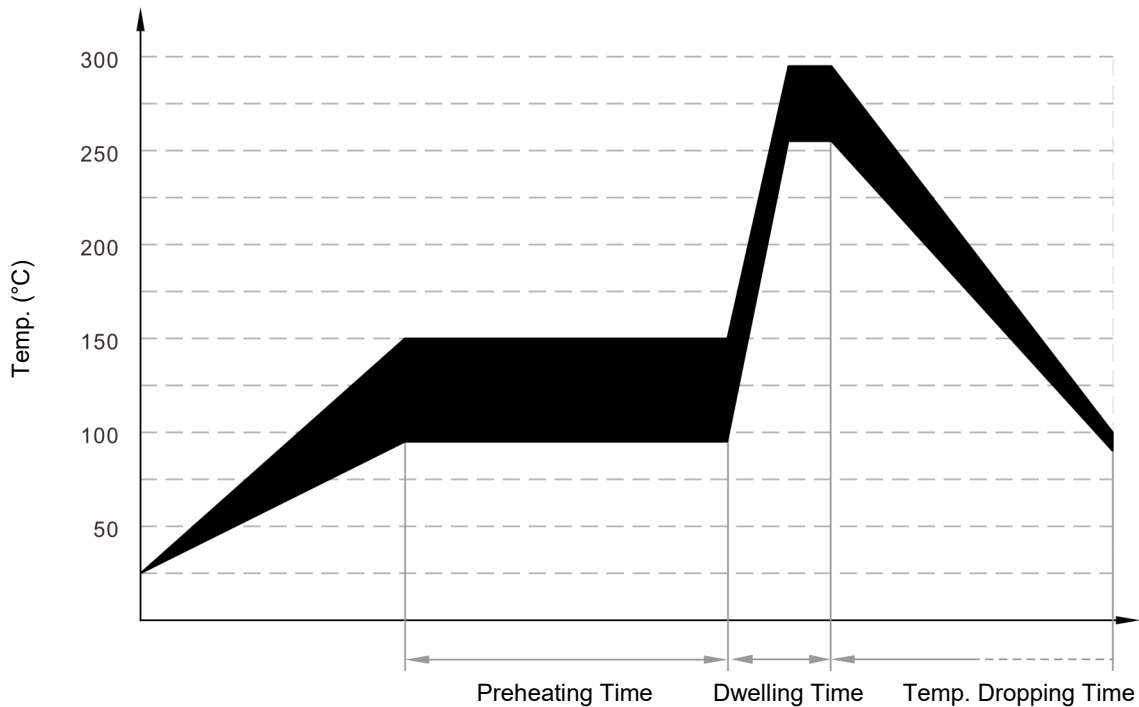

Wave Soldering Curve

Item	Temp. (°C)	Time (s)
Preheating	90 to 150	<150
Dwelling	255 to 290	3 to 10

Recommended Hand-Soldering Parameters

Item	Condition
Temp. of Solder Head	350 °C (max.)
Soldering Time	4 seconds (max.)

Packaging Information

- Bulk Packaging (Code: BUL)
- Bulk Packaging Quantity & Weight.

Series	Nominal Varistor Voltage	PE Bag	Box	Carton	G. W / Carton (365 × 265 × 245)
	(V)	(PCS)	(PCS)	(PCS)	(kg)±10%
14D	201 ~ 361	500	1000	6000	10 ~ 15
	391 ~ 621	400	800	4800	13 ~ 18
	681	250	500	3000	12

Note:
Other lead length packaging information, please contact SETsafe | SETfuse.

All Dimensions in mm

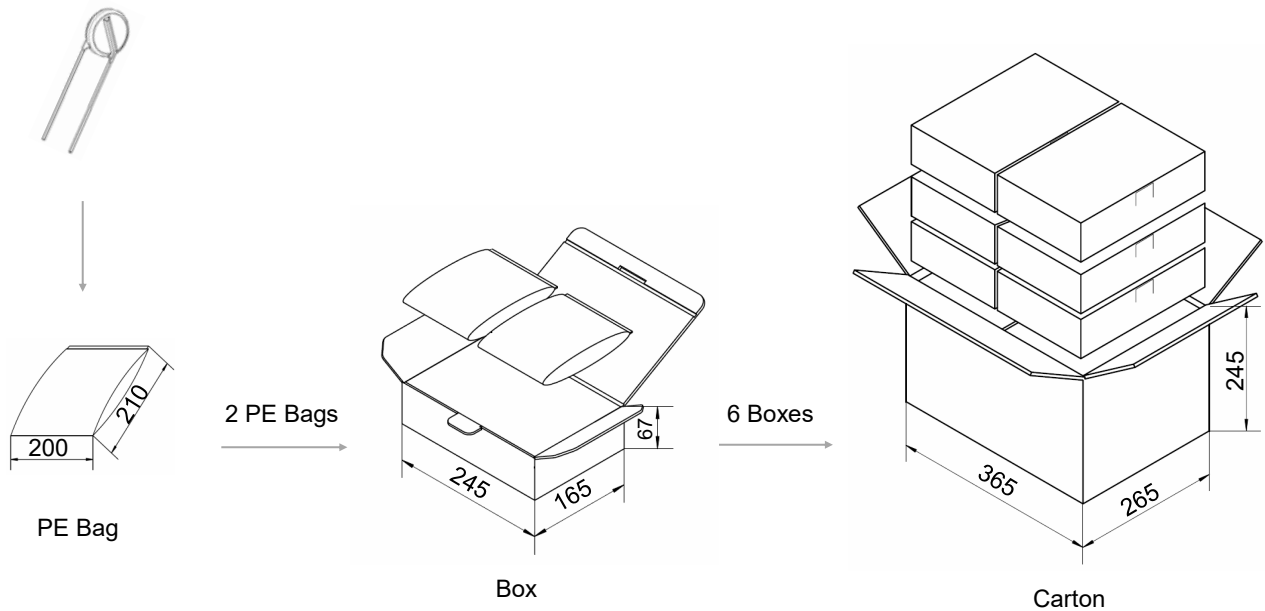

Packaging Information

- Tape Packaging (Code: 0AB)

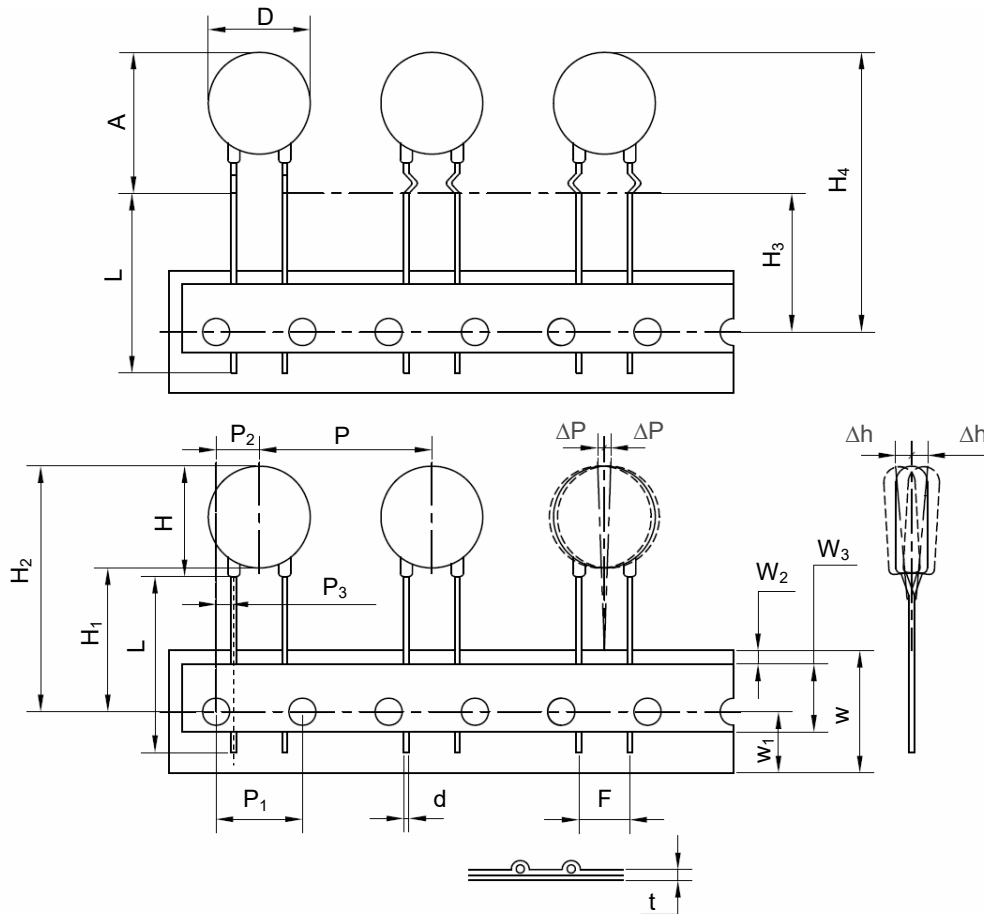

Dimensions (mm)

Symbol	Dimensions
P	25.4±1.0
P ₁	12.7±0.3
P ₂	6.35±1.3
P ₃	2.6±0.7
ΔP(max.)	1.0
W	18.0±1.0
W ₁	9.0±1.0
W ₂ (max.)	3.0
W ₃	10.0±2.0
H(max.)	18.5
H ₁	18.0 ^{+2.0} ₋₀
H ₂ (max.)	40.0
H ₃	18.0 ^{+2.0} ₋₀
H ₄ (max.)	42.0
Δh(max.)	2.0
t(max.)	0.6
D(max.)	16.5
D ₀	4.0±0.2
d	0.80±0.05
A(max.)	21.5
F	7.5±1.0
L(min.)	Taping

- Tape Packaging Quantity & Weight.

Series	Nominal Varistor Voltage (V)	Box (PCS)	Carton (PCS)	(365 × 265 × 415) G.W / Carton (kg)±10%
14D	681	300	2100	9
	471 - 621	400	2800	9 - 11
	301 - 431	500	3500	8 - 10
	201 - 271	600	4200	7 - 9

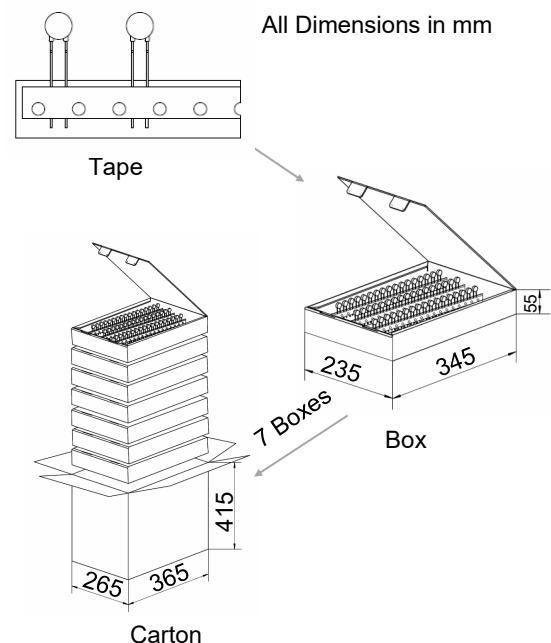

MOV

Metal Oxide Varistor

Packaging Information

- Tape Packaging (Code: 1AB)

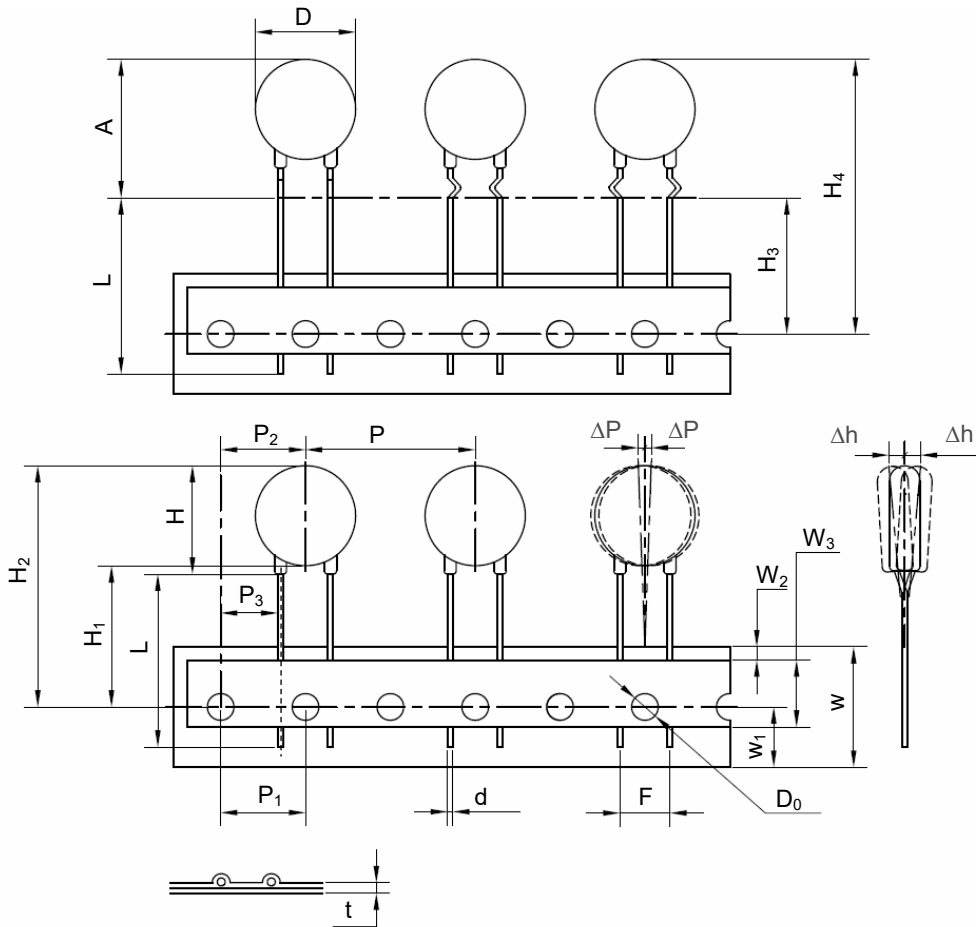

Dimensions (mm)

Symbol	Dimensions
P	25.4±1.0
P ₁	12.7±0.3
P ₂	12.7±1.3
P ₃	8.95±0.7
ΔP(max.)	1.0
W	18.0±1.0
W ₁	9.0±1.0
W ₂ (max.)	3.0
W ₃	10.0±2.0
H(max.)	18.5
H ₁	18.0 ^{+2.0} ₋₀
H ₂ (max.)	40.0
H ₃	18.0 ^{+2.0} ₋₀
H ₄ (max.)	42.0
Δh(max.)	2.0
t(max.)	0.6
D(max.)	16.5
D ₀	4.0±0.2
d	0.80±0.05
A(max.)	21.5
F	7.5±1.0
L(min.)	Taping

- Tape Packaging Quantity & Weight.

Series	Nominal Varistor Voltage (V)	Box (PCS)	Carton (PCS)	(365 × 265 × 415) G.W / Carton (kg)±10%
14D	681	300	2100	9
	471 - 621	400	2800	9 - 11
	301 - 431	500	3500	8 - 10
	201 - 271	600	4200	7 - 9

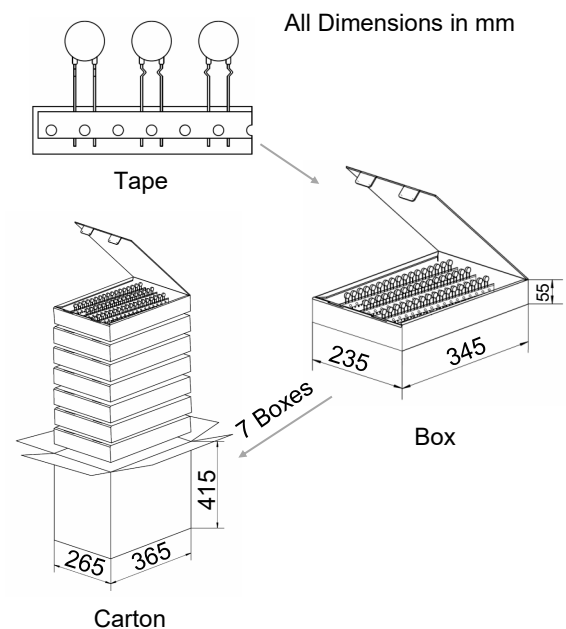

Packaging Information

- Tape Packaging (Code: 0EB)

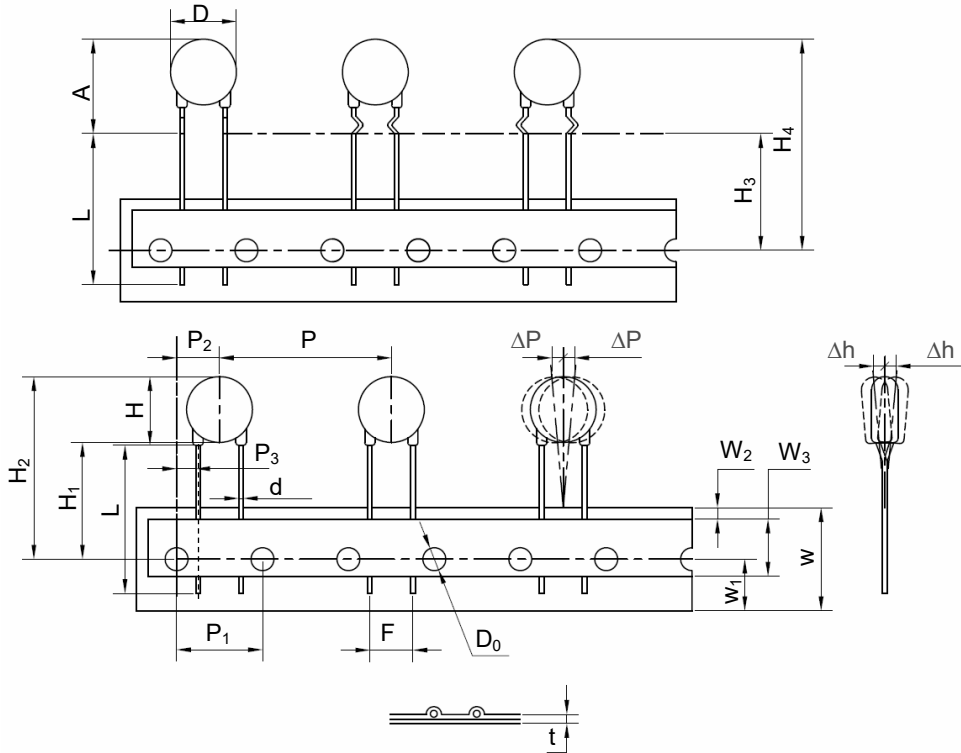

Dimensions (mm)

Symbol	Dimensions
P	30.0±1.0
P ₁	15.0±0.3
P ₂	7.5±1.3
P ₃	3.75±1.0
ΔP(max.)	1.0
W	18.0±1.0
W ₁	9.0±1.0
W ₂ (max.)	3.0
W ₃	10.0±2.0
H(max.)	18.5
H ₁	18.0 ^{+2.0} ₋₀
H ₂ (max.)	40.0
H ₃	18.0 ^{+2.0} ₋₀
H ₄ (max.)	42.0
Δh(max.)	2.0
t (max.)	0.6
D(max.)	16.5
D ₀	4.0±0.2
d	0.80±0.05
A(max.)	21.5
F	7.5±1.0
L(min.)	Taping

- Tape Packaging Quantity & Weight.

Series	Nominal Varistor Voltage (V)	Box (PCS)	Carton (PCS)	(365 × 265 × 415) G.W. / Carton (kg)±10%
14D	681	300	2100	8
	511 - 621	350	2450	8 - 9
	391 - 471	400	2800	7 - 9
	301 - 361	450	3150	7 - 9
	241 - 271	500	3500	6 - 7
	151			7
	201 - 221	550	3850	6 - 7

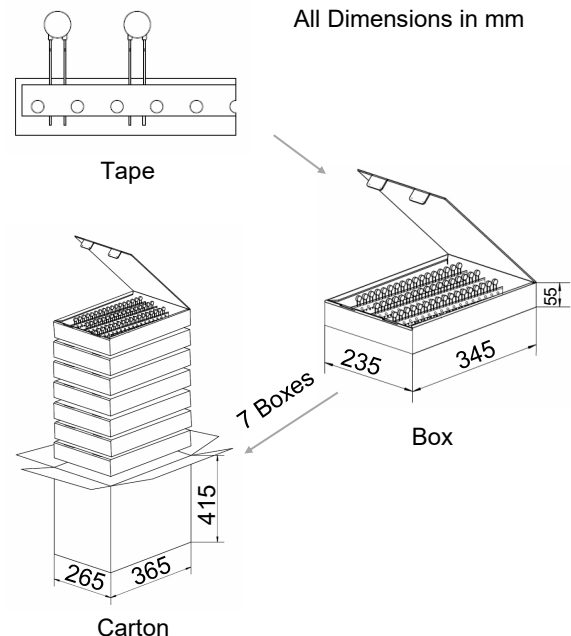

Packaging Information

- Tape Packaging (Code: 1EB)

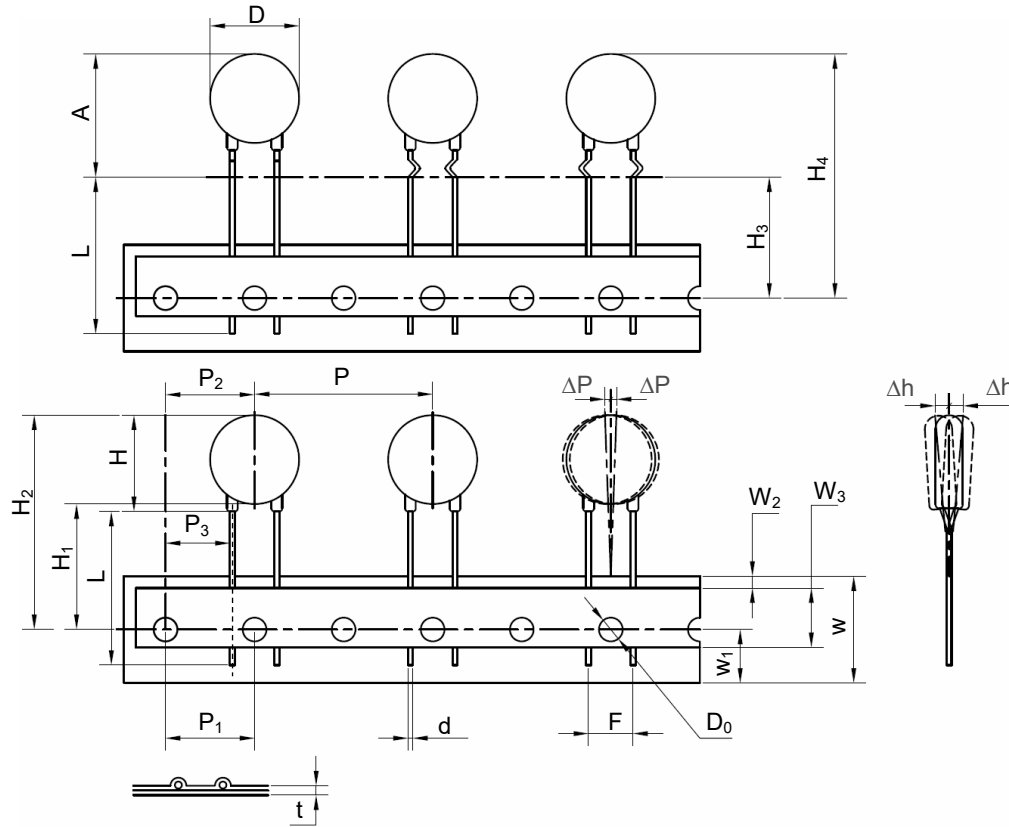

Dimensions (mm)

Symbol	Dimensions
P	30.0±1.0
P ₁	15.0±0.3
P ₂	15.0±1.3
P ₃	11.25±1.0
ΔP(max.)	1.0
W	18.0±1.0
W ₁	9.0±1.0
W ₂ (max.)	3.0
W ₃	10.0±1.0
H(max.)	18.5
H ₁	18.0 ^{+2.0} ₋₀
H ₂ (max.)	40.0
H ₃	18.0 ^{+2.0} ₋₀
H ₄ (max.)	42.0
Δh(max.)	2.0
t(max.)	0.55
D(max.)	16.5
D ₀	4.0±0.2
d	0.80±0.05
A(max.)	21.5
F	7.5±1.0
L(min.)	Taping

- Tape Packaging Quantity & Weight.

Series	Nominal Varistor Voltage	Box	Carton	(365 × 265 × 415) G.W. / Carton
14D	(V)	(PCS)	(PCS)	(kg)±10%
	681	300	2100	8
	511 - 621	350	2450	8 - 9
	391 - 471	400	2800	7 - 9
	301 - 361	450	3150	7 - 9
	241 - 271	500	3500	6 - 7
	151			7
201 - 221	550	3850	6 - 7	

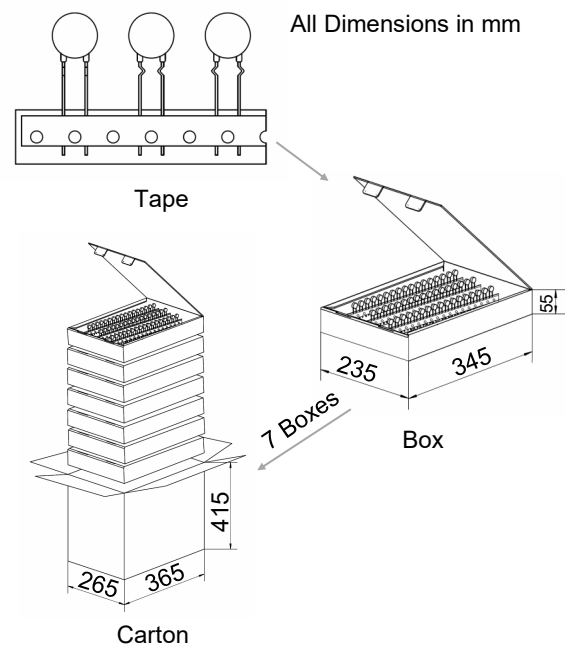

Packaging Information

- Reel Packaging (Code:1AR)

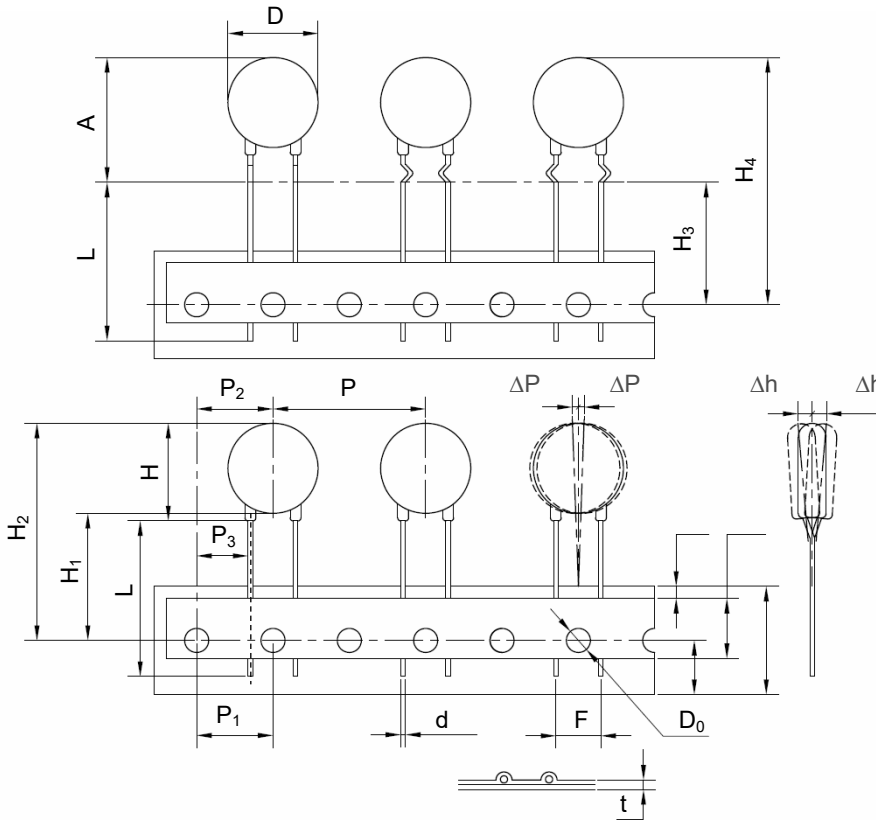

Dimensions (mm)

Symbol	Dimensions
P	25.4±1.0
P ₁	12.7±0.3
P ₂	12.7±1.3
P ₃	8.95±0.7
ΔP(max.)	1.0
W	18.0±1.0
W ₁	9.0±1.0
W ₂ (max.)	3.0
W ₃	10.0±2.0
H(max.)	18.5
H ₁	18.0 ^{+2.0} ₋₀
H ₂ (max.)	40.0
H ₃	18.0 ^{+2.0} ₋₀
H ₄ (max.)	42.0
Δh(max.)	2.0
t(max.)	0.6
D(max.)	16.5
D ₀	4.0±0.2
d	0.80±0.05
A(max.)	21.5
F	7.5±1.0
L(min.)	Taping

- Reel Packaging Quantity & Weight.

Series	Nominal Varistor Voltage (V)	Box (PCS)	Carton (PCS)	G. W / Carton (375 × 335 × 385) (kg)±10%
14D	201 - 301	650	3250	6 - 8
	331 - 681	400	2000	4 - 8

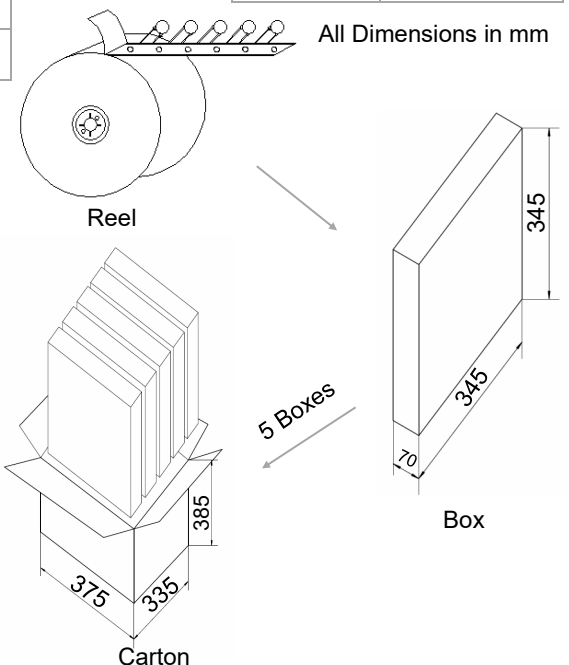
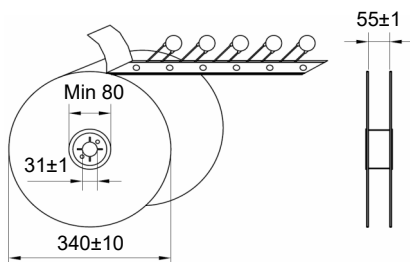



ATTENTION

Usage

1. Varistor must operated in the specified ambient temp.
2. Do not clean the varistor with strong polar solvent such as ketone, esters, benzene and halogenated hydrocarbon.
3. Please do not apply severe vibration, shock or pressure to MOV.
4. Please fix lead wires when bending or cutting. The distance between the bending point and the sealing of MOV shall be greater than 2 mm.

Replacement

If varistor is visually damaged, please replace it.

Storage

1. Storage Temp. Range: (-40 to +125) °C
2. Relative Humidity : ≤75% RH
3. Altitude: <2000 m
4. Do not store the MOV at the high temp., high humidity or corrosive gas environment, to avoid influencing the solder-ability of the lead wires, the product shall be used up within 1 year after receiving the goods.

Environmental Conditions

1. Varistor should neither be exposed to the open air, nor direct sunshine.
2. Varistor should avoid rain, water vapor or other condition of high temp. and high humidity.
3. Varistor should avoid sand dust, salt spray, or other harmful gases.

Max. Typical Capacitance of Varistor

The typical capacitance of varistor is listed in the specifications. Designers may refer to it when designing MOV in high frequency circuit.

Installation

Mechanical Stress

Do not knock MOV when installing, to avoid mechanical damage.