



Description

Metal Oxide Varistor (MOV) as one nonlinear resistance element is mainly made of zinc oxide (ZnO), which has very high surge capacity and big nonlinear coefficient. Below the threshold voltage, its resistance is very high, nearly no current flows through, but above the threshold voltage, the resistance reduces sharply, huge current can be discharged. Due to this characteristic, varistor as a protection component in electronic and electrical equipment can absorb abnormal over-voltage and lightning surge.

SETsafe | SETfuse varistor is with High Surge Current Density, Low Clamping Voltage, and Good Surge Capacity. It can also be customized as required.

Features

- Epoxy Resin Coating
- Silicone Resin Coating
- Low Leakage Current
- Bidirectional and Symmetrical V/I Characteristics
- RoHS & REACH Compliant

Applications

- Power Supplies
- Home Electrical Appliances
- Industrial Devices
- Surge Protectors
- Telecom Devices

Product Structure

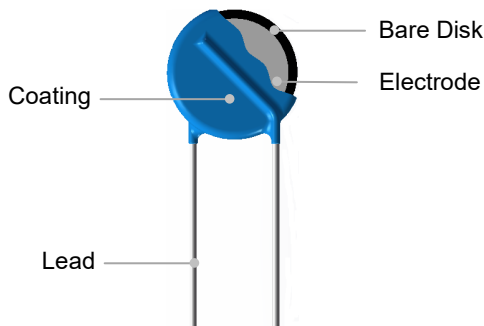

Lead Types

Lead Types		Codes
	Straight Lead	A
	Inward Crimp Lead	B
	Outward Crimp Lead	C
	Inline Crimp Lead	D
	Little Straight Lead	I

Agency Approvals

Agency	Standards	No.
	UL 1449 4 th Edition	on request
	CSA C22.2 NO.269.5-17	on request
	EN IEC 61051-1:2018 IEC 61051-2:1991+A1 IEC 61051-2-2:1991 Annex G.8.1 of IEC 62368-1:2018	on request
	GB/T 10193-1997 GB/T 10194-1997 GB 4943.1-2011 GB 8898-2011	on request

Marking

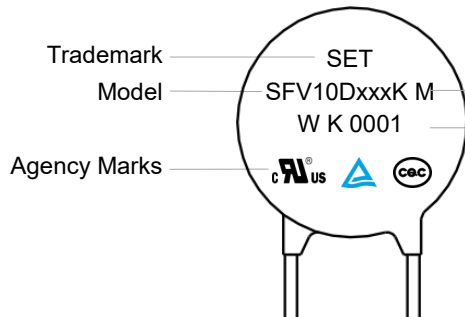

M: High Temp. Series of Epoxy	
Internal code	
Year Code	2000—A 2022—W
Surge Level	S: Normal Type K: Standard Type Q: Advanced Type
Serial No.	(E.G.: 0001)

Temp. Derating Curve

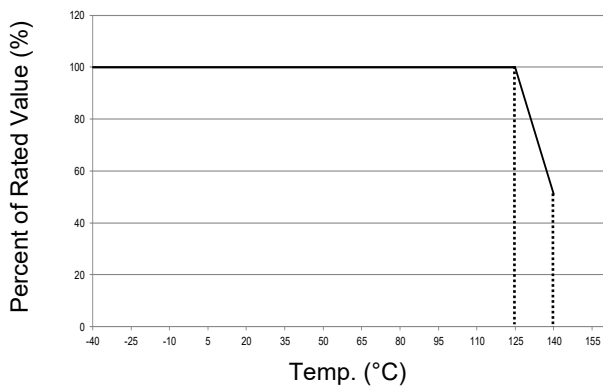

Note:

For high temp. series, when ambient temp. exceeds 125 °C, the peak surge current and energy rating should be reduced as shown in the left curve.

For High Temp. Series Products

General Technical Data

Item	Value	Unit
Operating Temperature	-40 to +125	°C
Storage Temperature	-40 to +150	°C
Voltage Proof	≥1000	V _{ac}
Insulation Resistance	≥100	MΩ

Part Numbering System

SFV 10 D 471 - K M K A BUL - 001

Other Options

*Packaging & Lead Length

BUL: Bulk + Standard Lead Length (Normal L28)

C35: Bulk + Cut to 3.5 mm

(Range:2.5 mm to 6 mm)

L30: Bulk + Special Lead Length 30 mm

(28 mm to 32 mm)

(0/1)AB: Taping + Box (Hole Pitch 12.7 mm)

(0/1)EB: Taping + Box (Hole Pitch 15.0 mm)

(0/1)AR: Taping + Reel (Hole Pitch 12.7 mm)

(0/1)ER: Taping + Reel (Hole Pitch 15.0 mm)

Note:0/1 Means Product Position

0: In Middle of Two Holes; 1: Across the Hole

Lead Types

A: Straight Lead

B: Inward Crimp Lead

C: Outward Crimp Lead

D: Inline Crimp Lead

I : Little Straight Lead

Surge Level

S: Normal Type

K: Standard Type

Q: Advanced Type

Operating Temp.

M: Epoxy Coating 125 °C

Voltage Tolerance

K: ±10%

J: ±5%

S: Special Tolerance

Nominal Varistor Voltage

220: $22 \times 10^0 = 22 \text{ V}$

471: $47 \times 10^1 = 470 \text{ V}$

122: $12 \times 10^2 = 1200 \text{ V}$

Disk Shape

D: Round

Bare Disk Dimension

10: 10 mm

Product Category

SETfuse Varistor

*For more details refer to packaging information.

Glossary

Item	Description
V_N	Nominal Varistor Voltage Voltage, at specified D.C. current used as a reference point in the component characteristics.
I_L	Leakage Current Measuring at 75% of varistor voltage.
UCT	Upper Category Temp. Max. ambient temp. for which a varistor has been designed to operate continuously.
LCT	Lower Category Temp. Minimum ambient temp. at which a varistor has been designed to operate continuously.
Max. Peak Current	Max. Peak Current Max. current per pulse, which may be passed by a varistor at an ambient temp. of 25 °C, for a given number of pulses.
V_C	Clamping Voltage Peak voltage developed across the varistor terminations under standard atmospheric conditions, when passing an 8/20 μs class current pulse.
Voltage Proof	Voltage Proof Max. peak voltage, which may be applied under continuous operating conditions between the varistor terminations and any conducting mounting surface (Applicable only to insulated varistors).
C_V	Capacitance Capacitance across the MOV measured at a specified frequency and voltage.
V_{ac}	Max. Continuous a.c. Voltage Max. a.c. r.m.s. voltage of a substantially sinusoidal waveform (less than 5% total harmonic distortion) which can be applied to the component under continuous operating conditions at 25 °C.
V_{dc}	Max. Continuous d.c. Voltage Max. d.c. voltage (with less than 5% ripple) which can be applied to the component under continuous operating conditions at an ambient temp. of 25 °C.

Specification

Model	Surge Level	Max. Continuous Operating Voltage		Varistor Voltage @1 mA DC		Clamping Voltage (Max.)		Max. Peak Current (1 time, 8/20 μs)	Max. Energy (10/1000 μs)	Typical Capacitance (For reference only) @1 kHz	Agency Approvals						
		Vac	Vdc	Min.	Max.	V _C	I _P				S		(pF)	UL	CUL	TUV	CQC
		(V)	(V)	(V)	(V)	(V)	(A)				(kA)	(J)					
SFV10D820KM	S	50	65	74	90	135	25	2.5	12	1200	●	●	●	●			
SFV10D101KM	S	60	85	90	110	165	25	2.5	15	1000	●	●	●	●			
SFV10D121KM	S	75	100	108	132	200	25	2.5	18	830	●	●	●	●			
SFV10D151KM	S	95	125	135	165	250	25	2.5	22	670	●	●	●	●			
SFV10D181KM	S	115	150	162	198	300	25	2.5	27	560	●	●	●	●			
SFV10D201KM	S	130	170	180	220	340	25	2.5	30	500	●	●	●	●			
SFV10D221KM	S	140	180	198	242	360	25	2.5	32	450	●	●	●	●			
SFV10D241KM	S	150	200	216	264	395	25	2.5	35	420	●	●	●	●			
SFV10D271KM	S	175	225	243	297	455	25	2.5	40	370	●	●	●	●			
SFV10D301KM	S	190	250	270	330	500	25	2.5	40	330	●	●	●	●			
SFV10D331KM	S	210	275	297	363	550	25	2.5	43	300	●	●	●	●			
SFV10D361KM	S	230	300	324	396	595	25	2.5	47	280	●	●	●	●			
SFV10D391KM	S	250	320	351	429	650	25	2.5	60	260	●	●	●	●			
SFV10D431KM	S	275	350	387	473	710	25	2.5	65	230	●	●	●	●			
SFV10D471KM	S	300	385	423	517	775	25	2.5	70	210	●	●	●	●			
SFV10D511KM	S	320	415	459	561	845	25	2.5	70	200	●	●	●	●			
SFV10D561KM	S	350	460	504	616	925	25	2.5	70	180	●	●	●	●			
SFV10D621KM	S	385	505	558	682	1025	25	2.5	70	160	●	●	●	●			
SFV10D681KM	S	420	560	612	748	1120	25	2.5	70	150	●	●	●	●			
SFV10D751KM	S	460	615	675	825	1240	25	2.5	75	130	●	●	●	●			
SFV10D821KM	S	510	670	738	902	1355	25	2.5	85	120	●	●	●	●			
SFV10D911KM	S	550	745	819	1001	1500	25	2.5	93	110	●	●	●	●			
SFV10D102KM	S	625	825	900	1100	1650	25	2.5	102	100	●	●	●	●			
SFV10D112KM	S	680	895	990	1210	1815	25	2.5	115	90	●	●	●	●			
SFV10D122KM	S	750	990	1080	1320	1980	25	2.5	125	55	●	●	●	●			

MOV

MOV





Specification

Model	Surge Level	Max. Continuous Operating Voltage		Varistor Voltage @1 mA DC		Clamping Voltage (Max.)		Max. Peak Current (1 time, 8/20 μs)	Max. Energy (10/1000 μs)	Typical Capacitance (For reference only) @1 kHz	Agency Approvals					
		Vac	Vdc	Min.	Max.	V _C	I _P				K	(pF)	UL	CUL	TUV	CQC
		(V)	(V)	(V)	(V)	(V)	(A)									
SFV10D820KM	K	50	65	74	90	135	25	3.5	14	1200	●	●	●	●		
SFV10D101KM	K	60	85	90	110	165	25	3.5	17	1000	●	●	●	●		
SFV10D121KM	K	75	100	108	132	200	25	3.5	20	830	●	●	●	●		
SFV10D151KM	K	95	125	135	165	250	25	3.5	25	670	●	●	●	●		
SFV10D181KM	K	115	150	162	198	300	25	3.5	30	560	●	●	●	●		
SFV10D201KM	K	130	170	180	220	340	25	3.5	35	500	●	●	●	●		
SFV10D221KM	K	140	180	198	242	360	25	3.5	39	450	●	●	●	●		
SFV10D241KM	K	150	200	216	264	395	25	3.5	42	420	●	●	●	●		
SFV10D271KM	K	175	225	243	297	455	25	3.5	49	370	●	●	●	●		
SFV10D301KM	K	190	250	270	330	500	25	3.5	54	330	●	●	●	●		
SFV10D331KM	K	210	275	297	363	550	25	3.5	58	300	●	●	●	●		
SFV10D361KM	K	230	300	324	396	595	25	3.5	65	280	●	●	●	●		
SFV10D391KM	K	250	320	351	429	650	25	3.5	70	260	●	●	●	●		
SFV10D431KM	K	275	350	387	473	710	25	3.5	80	230	●	●	●	●		
SFV10D471KM	K	300	385	423	517	775	25	3.5	85	210	●	●	●	●		
SFV10D511KM	K	320	415	459	561	845	25	3.5	90	200	●	●	●	●		
SFV10D561KM	K	350	460	504	616	925	25	3.5	92	180	●	●	●	●		
SFV10D621KM	K	385	505	558	682	1025	25	3.5	95	160	●	●	●	●		
SFV10D681KM	K	420	560	612	748	1120	25	3.5	98	150	●	●	●	●		
SFV10D751KM	K	460	615	675	825	1240	25	3.5	100	130	●	●	●	●		
SFV10D821KM	K	510	670	738	902	1355	25	3.5	110	120	●	●	●	●		
SFV10D911KM	K	550	745	819	1001	1500	25	3.5	130	110	●	●	●	●		
SFV10D102KM	K	625	825	900	1100	1650	25	3.5	140	100	●	●	●	●		
SFV10D112KM	K	680	895	990	1210	1815	25	3.5	155	90	●	●	●	●		
SFV10D122KM	K	750	990	1080	1320	1980	25	3.5	170	55	●	●	●	●		

MOV

MOV

Specification

Model	Surge Level	Max. Continuous Operating Voltage		Varistor Voltage @1 mA DC		Clamping Voltage (Max.)		Pulse Impact Performance (40 times) (1.2/50 μs & 8/20 μs)	Max. Energy (10/1000 μs)	Typical Capacitance (For reference only) @1 kHz	Agency Approvals					
		Vac	Vdc	Min.	Max.	V _C	I _P				Q	(pF)				
		(V)	(V)	(V)	(V)	(V)	(A)						(kV)	(J)	UL	CUL
SFV10D201KM	Q	130	170	180	220	340	25	4.5	35	500	•	•	•	•		
SFV10D221KM	Q	140	180	198	242	360	25	4.5	39	450	•	•	•	•		
SFV10D241KM	Q	150	200	216	264	395	25	4.5	42	420	•	•	•	•		
SFV10D271KM	Q	175	225	243	297	455	25	4.5	49	370	•	•	•	•		
SFV10D301KM	Q	190	250	270	330	500	25	4.5	54	330	•	•	•	•		
SFV10D331KM	Q	210	275	297	363	550	25	4.5	58	300	•	•	•	•		
SFV10D361KM	Q	230	300	324	396	595	25	4.5	65	280	•	•	•	•		
SFV10D391KM	Q	250	320	351	429	650	25	4.5	70	260	•	•	•	•		
SFV10D431KM	Q	275	350	387	473	710	25	4.5	80	230	•	•	•	•		
SFV10D471KM	Q	300	385	423	517	775	25	4.5	85	210	•	•	•	•		
SFV10D511KM	Q	320	415	459	561	845	25	4.5	90	200	•	•	•	•		
SFV10D561KM	Q	350	460	504	616	925	25	4.5	92	180	•	•	•	•		
SFV10D621KM	Q	385	505	558	682	1025	25	4.5	95	160	•	•	•	•		
SFV10D681KM	Q	420	560	612	748	1120	25	4.5	98	150	•	•	•	•		

MOV

MOV

Dimensions (mm)

Model	L (Min.)	H (Max.)	T (Max.)	D (Max.)	d	F	F ₁	A (Max.)
SFV10D820KM	20	15.5	4.4	12.5	0.80±0.05	7.5±0.6	1.2 - 2.6	17.5
SFV10D101KM	20	15.5	4.6	12.5	0.80±0.05	7.5±0.6	1.3 - 2.8	17.5
SFV10D121KM	20	15.5	4.8	12.5	0.80±0.05	7.5±0.6	1.4 - 3.0	17.5
SFV10D151KM	20	15.5	5.1	12.5	0.80±0.05	7.5±0.6	1.6 - 3.3	17.5
SFV10D181KM	20	15.5	4.4	12.5	0.80±0.05	7.5±0.6	1.2 - 2.7	17.5
SFV10D201KM	20	15.5	4.6	12.5	0.80±0.05	7.5±0.6	1.3 - 2.9	17.5
SFV10D221KM	20	15.5	4.7	12.5	0.80±0.05	7.5±0.6	1.4 - 3.0	17.5
SFV10D241KM	20	15.5	4.8	12.5	0.80±0.05	7.5±0.6	1.4 - 3.1	17.5
SFV10D271KM	20	15.5	4.9	12.5	0.80±0.05	7.5±0.6	1.5 - 3.2	17.5
SFV10D301KM	20	15.5	5.1	12.5	0.80±0.05	7.5±0.6	1.6 - 3.4	17.5
SFV10D331KM	20	15.5	5.3	12.5	0.80±0.05	7.5±0.6	1.7 - 3.5	17.5
SFV10D361KM	20	15.5	5.4	12.5	0.80±0.05	7.5±0.6	1.9 - 3.7	17.5
SFV10D391KM	20	15.5	5.6	12.5	0.80±0.05	7.5±0.6	2.0 - 3.9	17.5
SFV10D431KM	20	15.5	5.8	12.5	0.80±0.05	7.5±0.6	2.1 - 4.1	17.5
SFV10D471KM	20	15.5	6.1	12.5	0.80±0.05	7.5±0.6	2.3 - 4.3	17.5
SFV10D511KM	20	15.5	6.3	12.5	0.80±0.05	7.5±0.6	2.5 - 4.5	17.5
SFV10D561KM	20	15.5	6.6	12.5	0.80±0.05	7.5±0.6	2.7 - 4.7	17.5
SFV10D621KM	20	15.5	6.9	12.5	0.80±0.05	7.5±0.6	3.1 - 5.1	17.5
SFV10D681KM	20	15.5	7.2	12.5	0.80±0.05	7.5±0.6	3.4 - 5.4	17.5
SFV10D751KM	20	15.5	7.6	12.5	0.80±0.05	7.5±0.6	3.7 - 5.7	17.5
SFV10D821KM	20	15.5	8.0	12.5	0.80±0.05	7.5±0.6	4.1 - 6.1	17.5
SFV10D911KM	20	15.5	8.5	12.5	0.80±0.05	7.5±0.6	4.6 - 6.6	17.5
SFV10D102KM	20	15.5	9.0	12.5	0.80±0.05	7.5±0.6	5.1 - 7.1	17.5
SFV10D112KM	20	15.5	9.6	12.5	0.80±0.05	7.5±0.6	5.6 - 7.6	17.5
SFV10D122KM	20	15.5	10.1	12.5	0.80±0.05	7.5±0.6	6.1 - 8.1	17.5

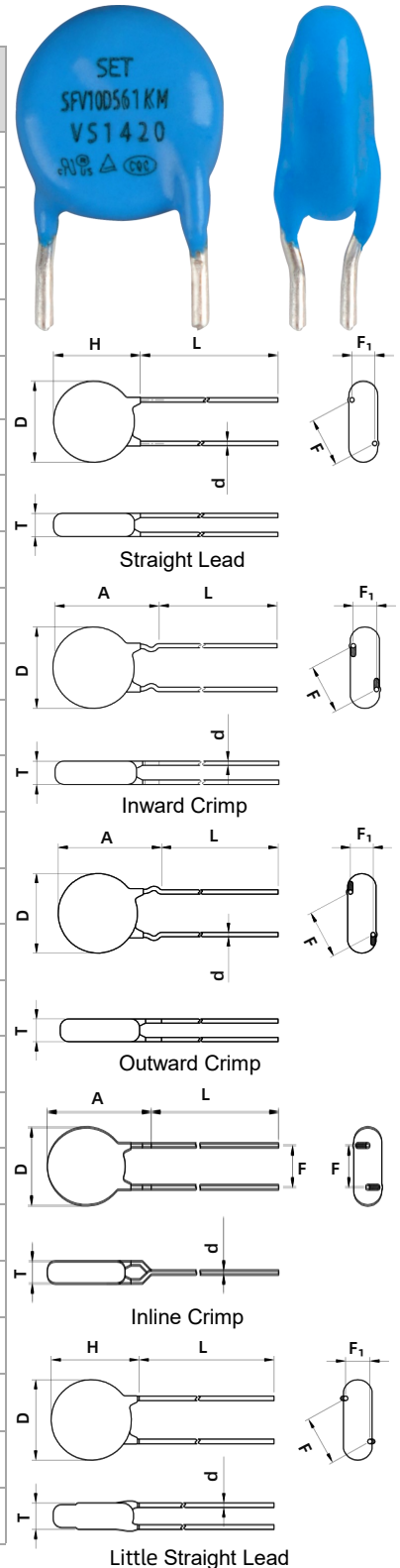

Note:

The above data is for reference only.

Performance Curve (For reference only)

- Max. Peak Current Derating Curves

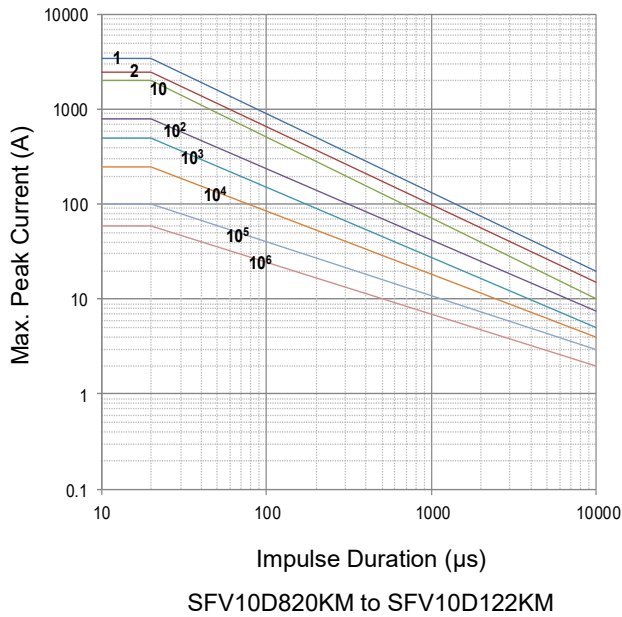

Note: 1, 2, 10, 10², 10³, 10⁴, 10⁵, 10⁶ Stand for Repetitions.

- Voltage-Current Characteristic Curves

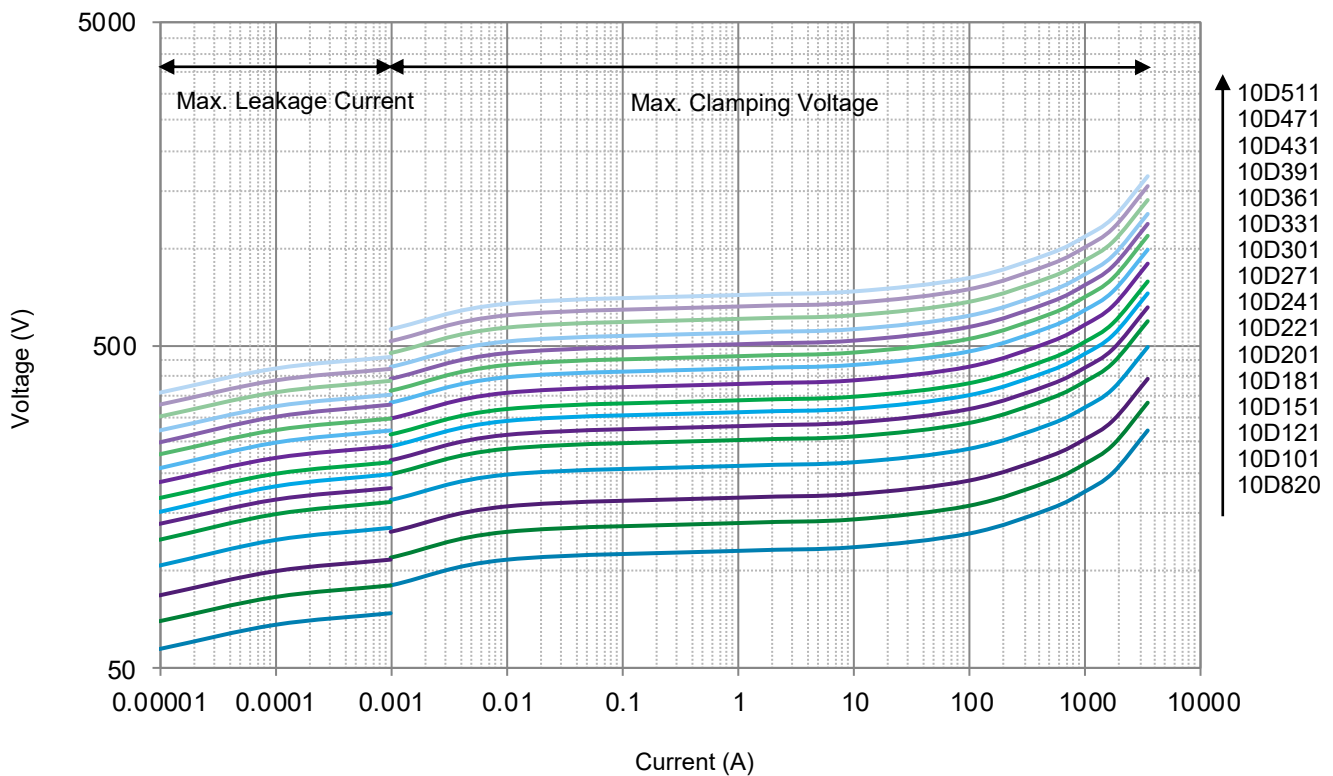

- Voltage-Current Characteristic Curves

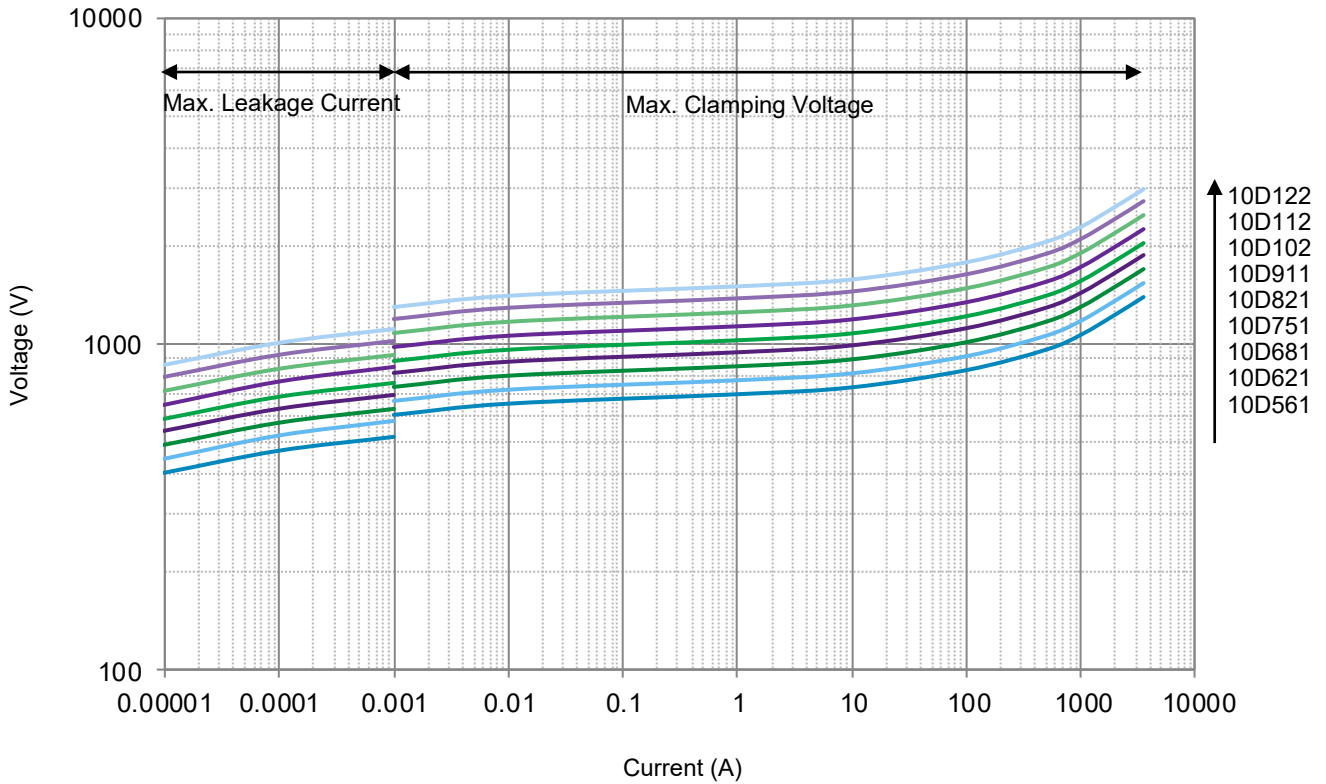

Soldering Parameters

Wave Soldering Parameters

The wave soldering parameters are for reference only. When MOV is for practice use, some related validation is recommended.

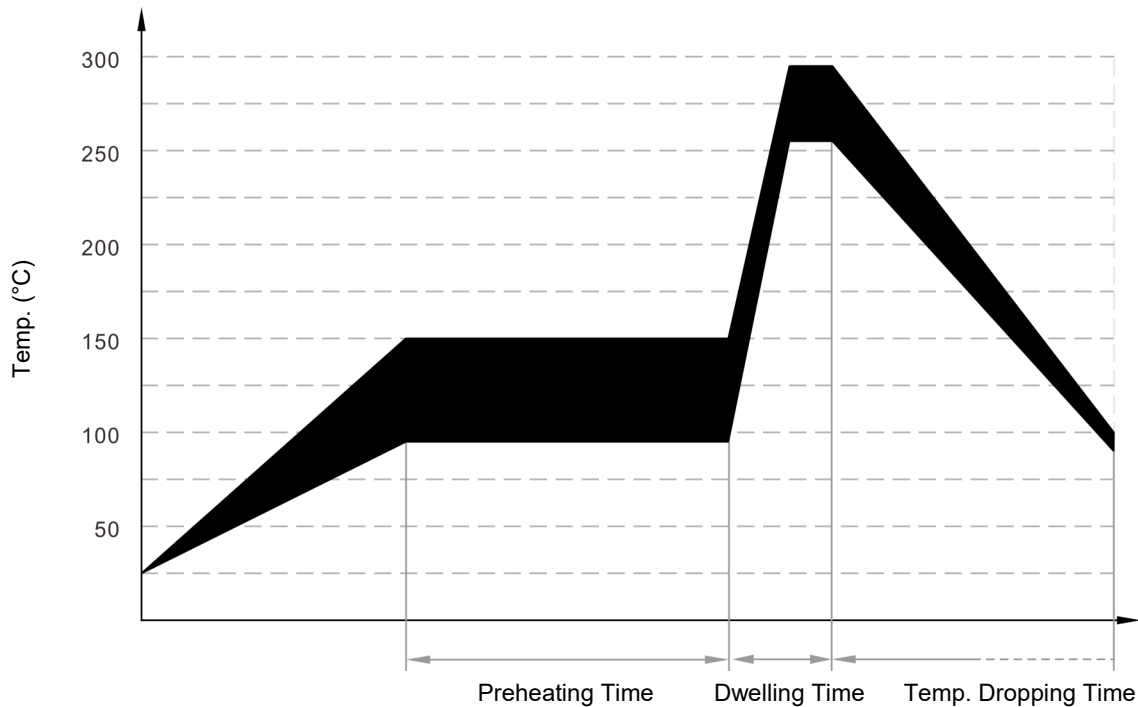

Wave Soldering Curve

Item	Temp. (°C)	Time (s)
Preheating	90 to 150	<150
Dwelling	255 to 290	3 to 10

Recommended Hand-Soldering Parameters

Item	Condition
Temp. of Solder Head	350 °C (max.)
Soldering Time	4 seconds (max.)

Packaging Information

- Bulk Packaging (Code: BUL)
- Bulk Packaging Quantity & Weight.

Series	Nominal Varistor Voltage	PE Bag	Box	Carton	G. W / Carton (365 × 265 × 245)
	(V)	(PCS)	(PCS)	(PCS)	(kg)±10%
10D	820 - 821	500	1000	6000	5 - 13
	911 - 122	400	800	4800	13-17

Note:

Other lead length packaging information, please contact SETsafe | SETfuse.

All Dimensions in mm

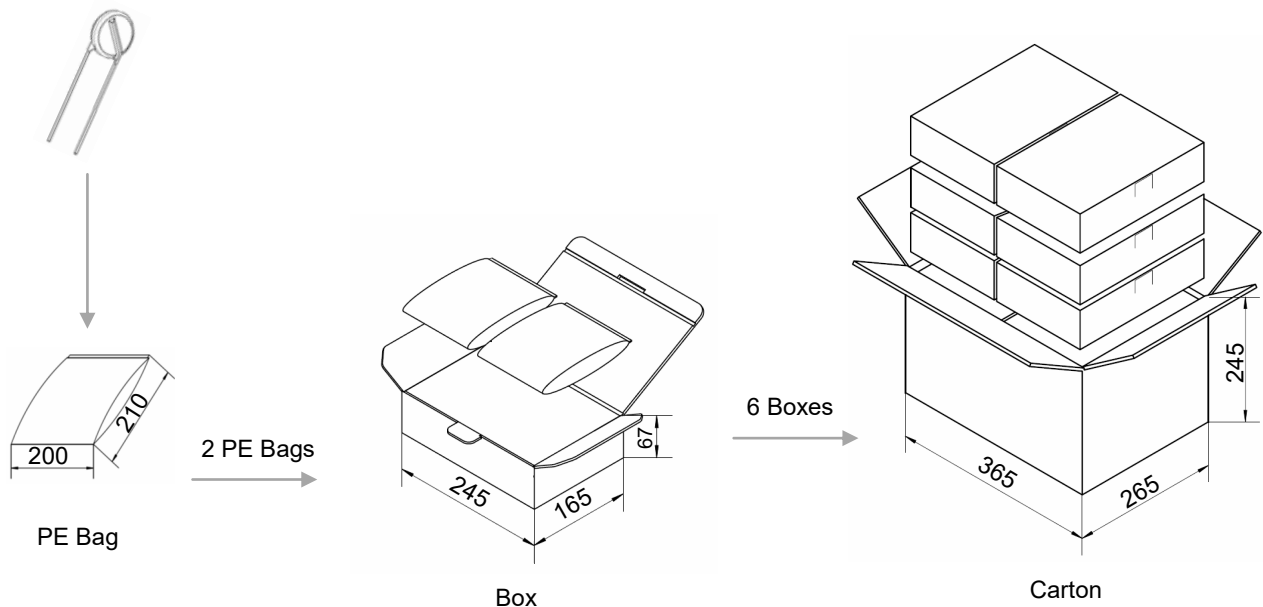

Packaging Information

- Tape Packaging (Code: 0AB)

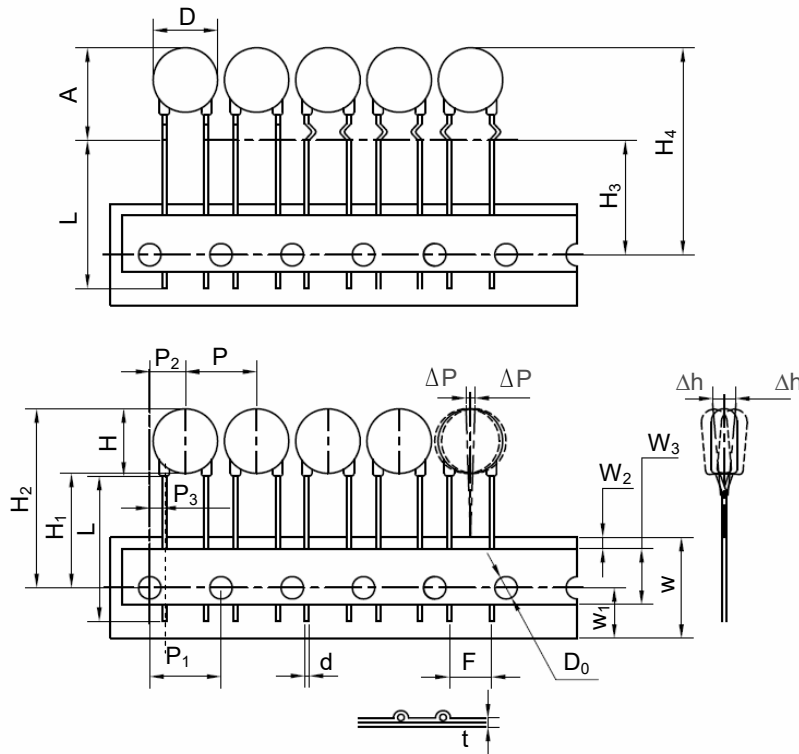

Dimensions (mm)

Symbol	Dimensions
P	12.7±1.0
P ₁	12.7±0.3
P ₂	6.35±1.30
P ₃	2.6±0.7
ΔP(max.)	1.0
W	18.0±1.0
W ₁	9.0±1.0
W ₂ (max.)	3.0
W ₃	10.0±2.0
H(max.)	15.5
H ₁	18.0 ^{+2.0} ₋₀
H ₂ (max.)	36.0
H ₃	18.0 ^{+2.0} ₋₀
H ₄ (max.)	38.0
Δh(max.)	2.0
t(max.)	0.6
D(max.)	12.5
D ₀	4.0±0.2
d	0.80±0.05
A(max.)	17.5
F	7.5±1.0
L(min.)	Taping

- Tape Packaging Quantity & Weight.

Series	Nominal Varistor Voltage (V)	Box (PCS)	Carton (PCS)	G. W / Carton (365 × 265 × 415) (kg)±10%
10D	112 - 122	550	3850	12 - 13
	911 - 102	600	4200	11 - 13
	751 - 821	700	4900	11 - 13
	471 - 681	800	5600	9 - 13
	391 - 431	1000	7000	10 - 11
	331 - 361	1100	7700	10 - 11
	271 - 301	1200	8400	10 - 11
	151			
	180 - 241	1300	9100	9 - 11
	820 - 121			8 - 10

All Dimensions in mm

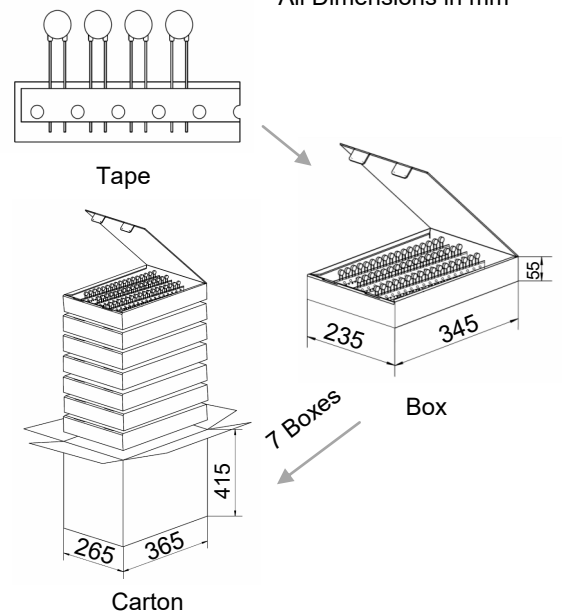

Packaging Information

- Tape Packaging (Code: 1AB)

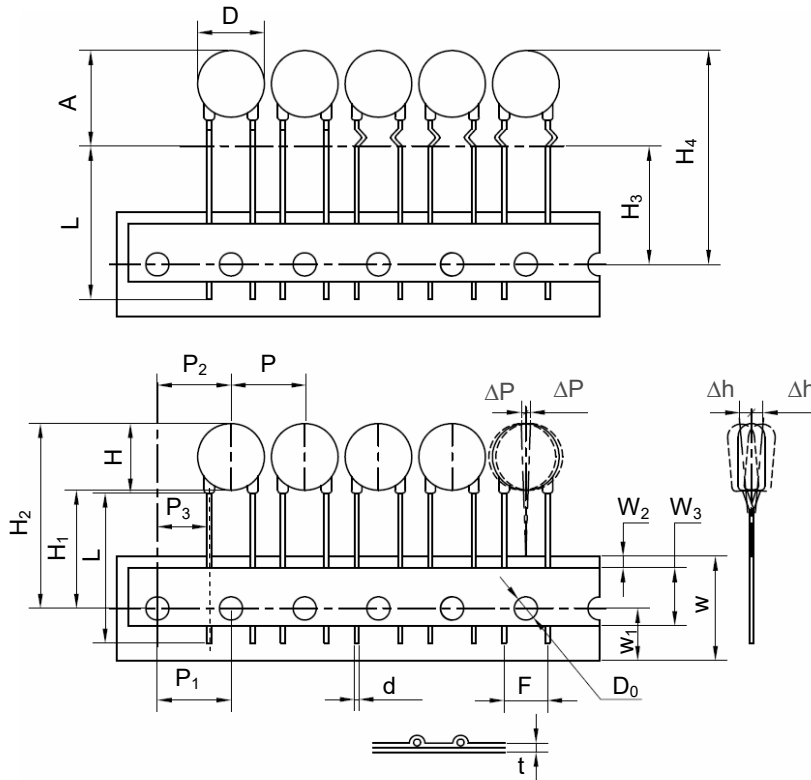

Dimensions (mm)

Symbol	Dimensions
P	12.7±1.0
P ₁	12.7±0.3
P ₂	12.7±1.30
P ₃	8.95±0.7
ΔP(max.)	1.0
W	18.0±1.0
W ₁	9.0±1.0
W ₂ (max.)	3.0
W ₃	10.0±2.0
H(max.)	15.5
H ₁	18.0 ^{+2.0} ₋₀
H ₂ (max.)	36.0
H ₃	18.0 ^{+2.0} ₋₀
H ₄ (max.)	38.0
Δh(max.)	2.0
t(max.)	0.6
D(max.)	12.5
D ₀	4.0±0.2
d	0.80±0.05
A(max.)	17.5
F	7.5±1.0
L(min.)	Taping

- Tape Packaging Quantity & Weight.

Series	Nominal Varistor Voltage	Box	Carton	G. W / Carton (365 × 265 × 415)
	(V)	(PCS)	(PCS)	(kg)±10%
10D	112 - 122	550	3850	12 - 13
	911 - 102	600	4200	11 - 13
	751 - 821	700	4900	11 - 13
	471 - 681	800	5600	9 - 13
	391 - 431	1000	7000	10 - 11
	331 - 361	1100	7700	10 - 11
	271 - 301	1200	8400	10 - 11
	151			
	180 - 241	1300	9100	9 - 11
	820 - 121			8 - 10

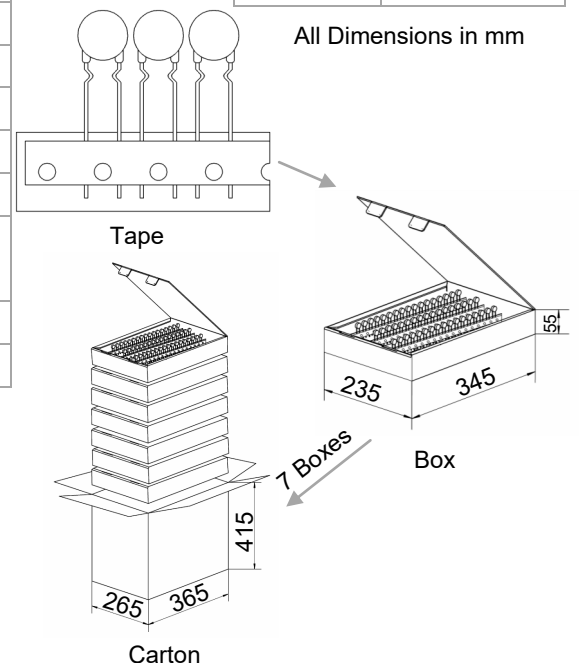

Packaging Information

- Tape Packaging (Code: 0EB)

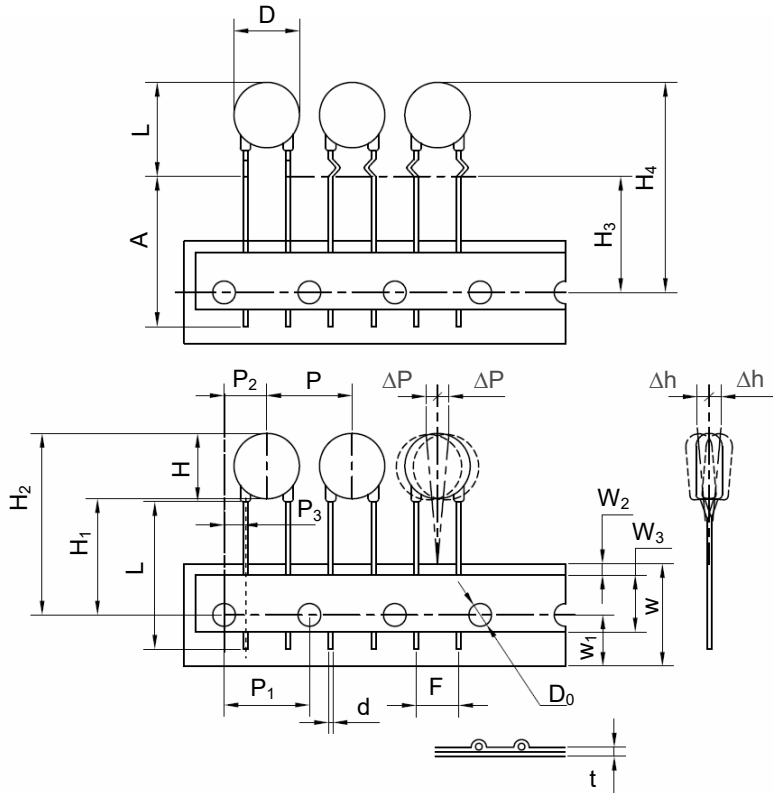

Dimensions (mm)

Symbol	Dimensions
P	15.0±1.0
P ₁	15.0±0.3
P ₂	7.5±1.3
P ₃	3.75±1.0
ΔP(max.)	1.0
W	18.0±1.0
W ₁	9.0±1.0
W ₂ (max.)	3.0
W ₃	10.0±2.0
H(max.)	15.5
H ₁	18.0 ^{+2.0} ₋₀
H ₂ (max.)	36.0
H ₃	18.0 ^{+2.0} ₋₀
H ₄ (max.)	38.0
Δh(max.)	2.0
t (max.)	0.6
D(max.)	12.5
D ₀	4.0±0.2
d	0.80±0.05
A(max.)	17.5
F	7.5±1.0
L(min.)	Taping

- Tape Packaging Quantity & Weight.

Series	Nominal Varistor Voltage (V)	Box (PCS)	Carton (PCS)	G. W / Carton (365 × 265 × 415) (kg)±10%
10D	911 - 122	500	3500	9 - 12
	751 - 821	600	4200	10 - 11
	621 - 681	700	4900	10 - 11
	431 - 561	800	5600	8 - 11
	271 - 391	1000	7000	8 - 10
	151			9 - 10
	201 - 241	1100	7700	8 - 9
	121			
	181	1200	8400	7 - 8
	820 - 101			

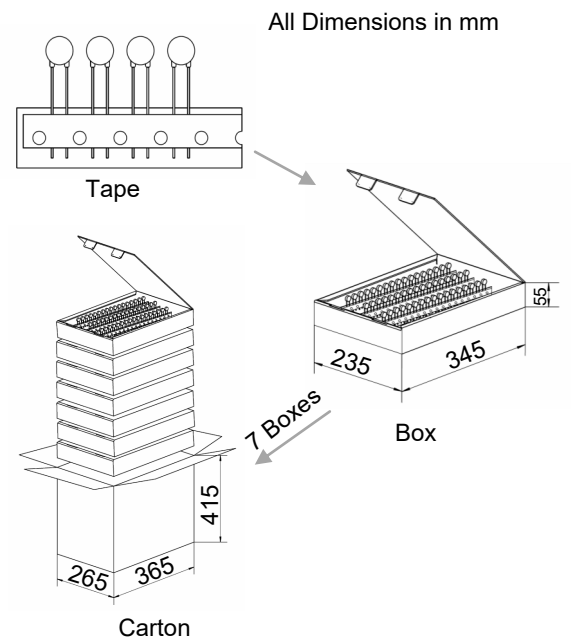

Packaging Information

- Reel Packaging (Code:0AR)

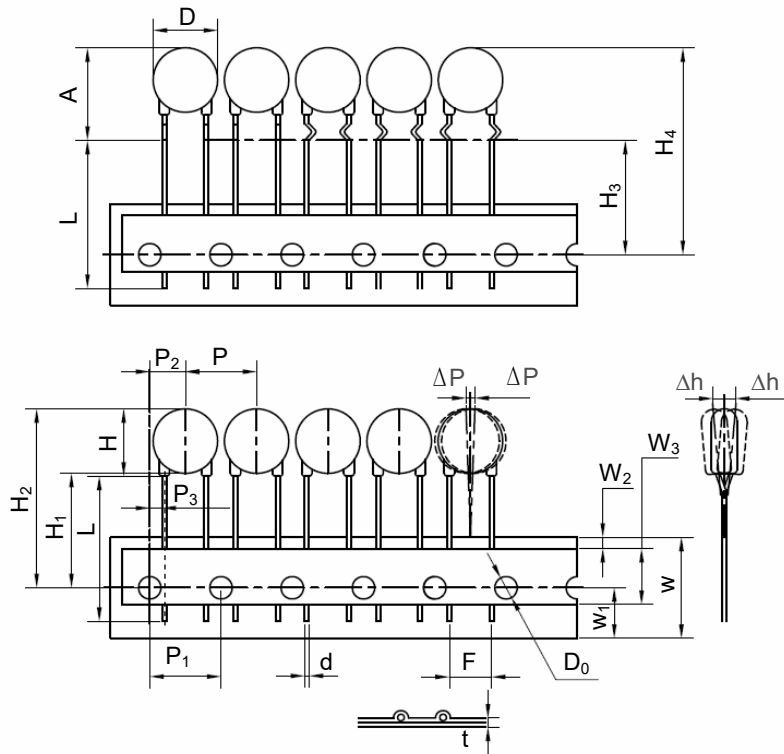

Dimensions (mm)

Symbol	Dimensions
P	12.7±1.0
P ₁	12.7±0.3
P ₂	6.35±1.30
P ₃	2.6±0.7
ΔP(max.)	1.0
W	18.0±1.0
W ₁	9.0±1.0
W ₂ (max.)	3.0
W ₃	10.0±1.0
H(max.)	15.5
H ₁	18.0 ^{+2.0} ₋₀
H ₂ (max.)	36.0 ^{+2.0} ₋₀
H ₃	18.0
H ₄ (max.)	38.0
Δh(max.)	2.0
t(max.)	0.6
D(max.)	12.5
D ₀	4.0±0.2
d	0.80±0.05
A(max.)	17.5
F	7.5±1.0
L(min.)	Taping

- Reel Packaging Quantity & Weight.

Series	Nominal Varistor Voltage	Box	Carton	G. W / Carton (375 × 335 × 385)
	(V)	(PCS)	(PCS)	(kg)±10%
10D	820 - 391	1500	7500	6 - 11
	431 - 561	1000	5000	8 - 10
	621 - 821	800	4000	8 - 11
	911 - 122	500	2500	7 - 9

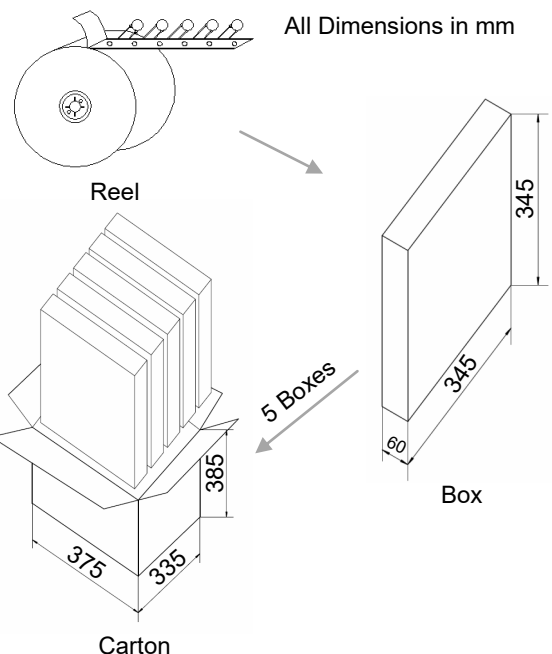
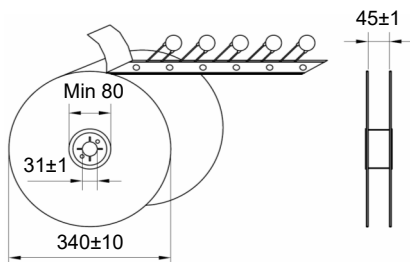



ATTENTION

Usage

1. Varistor must operated in the specified ambient temp.
2. Do not clean the varistor with strong polar solvent such as ketone, esters, benzene and halogenated hydrocarbon.
3. Please do not apply severe vibration, shock or pressure to MOV.
4. Please fix lead wires when bending or cutting. The distance between the bending point and the sealing of MOV shall be greater than 2 mm.

Replacement

If varistor is visually damaged, please replace it.

Storage

1. Storage Temp. Range: (-40 to +125) °C
2. Relative Humidity : ≤75% RH
3. Altitude: <2000 m
4. Do not store the MOV at the high temp., high humidity or corrosive gas environment, to avoid influencing the solder-ability of the lead wires, the product shall be used up within 1 year after receiving the goods.

Environmental Conditions

1. Varistor should neither be exposed to the open air, nor direct sunshine.
2. Varistor should avoid rain, water vapor or other condition of high temp. and high humidity.
3. Varistor should avoid sand dust, salt spray, or other harmful gases.

Max. Typical Capacitance of Varistor

The typical capacitance of varistor is listed in the specifications. Designers may refer to it when designing MOV in high frequency circuit.

Installation

Mechanical Stress

Do not knock MOV when installing, to avoid mechanical damage.