

Without Tube

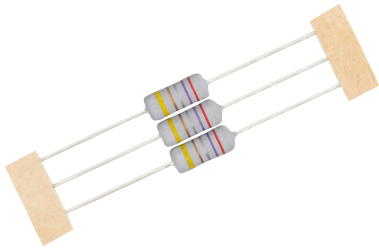

Dimensions (mm)

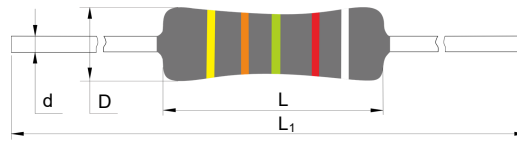

L	L ₁	D	d
11.0 ± 1.0	60.0 / 72.0 ± 2.0	Φ4.5 ± 0.5	Φ0.70 ± 0.05

With Tube

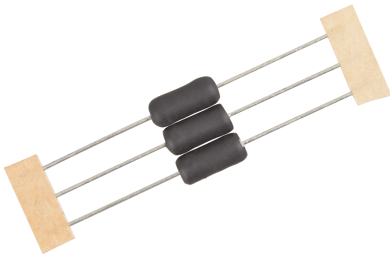

L	L ₁	D	d
12.0 ± 1.0	60.0 / 72.0 ± 2.0	Φ4.8 ± 0.5	Φ0.70 ± 0.05

Note: Blue font is SETsafe | SETfuse common length

Description

Fusible Wirewound Resistor (RXF) is a power resistor, which is made by winding a resistive element on a ceramic core, and the core is coated by insulation coating.

Features

- Surge Protection
- Over Current Protection
- Inrush Current Protection
- Miniaturized Product
- RoHS & REACH Compliant

Applications

- Switch Mode Power Supply (SMPS)
- Adapters
- LED Drivers
- Small Power Home Appliances

Structure Diagram

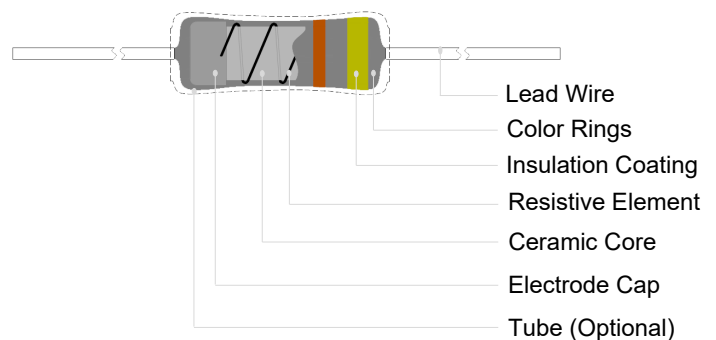

Agency Approvals

Agency	Standards	File No.	Resistance Range
 UL E324712	UL1412	on request	0.27 Ω ~ 1,000 Ω
 VDE REG E012	IEC 62368-1	on request	0.27 Ω ~ 1,000 Ω
 CQC V019518	SJ 2865	on request	3.0 Ω ~ 68 Ω

Technical Parameter

Item	Parameter
Rated Power (P)	2 W
Rated Resistance	0.27 Ω ~ 1,000 Ω
Resistance Tolerance	5% (E24) , 10% (E12)
Rated Current (I _N)	$I_N = \sqrt{P / R}$
Rated Voltage (U _N)	$U_N = \sqrt{P \times R}$
Surge	2.0 kV (R > 10 Ω)
	1.0 kV (R ≤ 10 Ω)

Part Numbering System

RXF21 SC 4R7 J - T 60 M A - 001

Other Options

Tube

A: Without Tube
B: With Tube

TCR

M: ± 350 (10⁻⁶ / °C)
T: 800 to 5000 (10⁻⁶ / °C)

Total Length

60: 60 mm
72: 72 mm

Packaging

T: Taping
B: Bulk

Tolerance

J: ± 5%
K: ± 10%

Rated Resistance

R47: 0.47 Ω
4R7: 4.7 Ω
47R: 47 Ω
470R: 470 Ω

Rated Power

SC: 2 W

Product Category

RXF: Fusible Wirewound Resistor

Rated Power Derating Curve (For Reference Only)

When the ambient temp. exceeds 25 °C, the rated power value declines as the following curve.

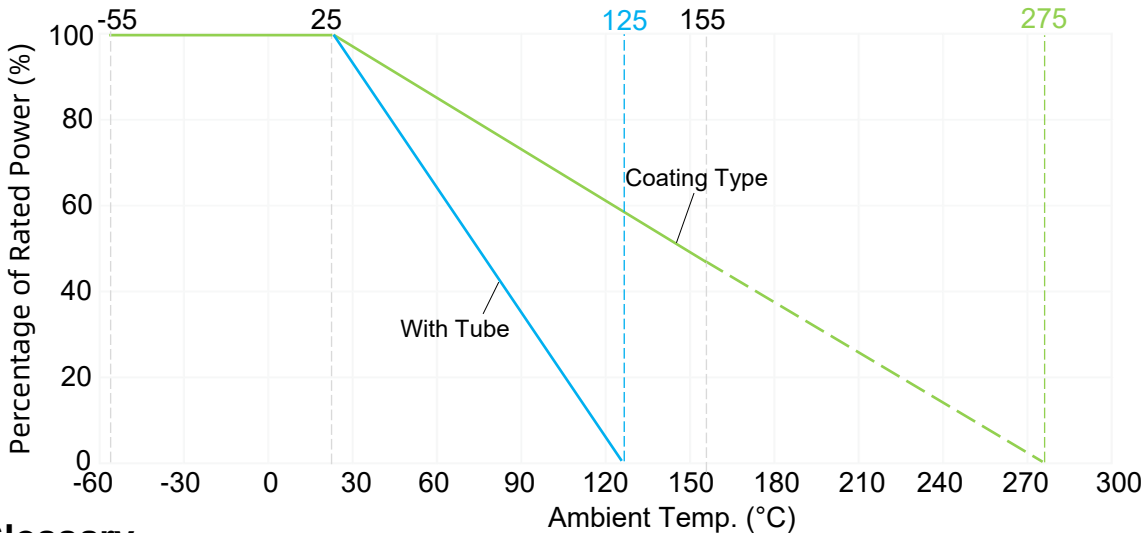

(The Max. working temp. of polyolefin tube is 125 °C)



Glossary

Item	Description
U _N	Rated Voltage The d.c. or a.c. r.m.s. voltage calculated from the square root of the product of the rated resistance and the rated dissipation.
TCR	Temp. Coefficient of Resistance Relative variation of resistance between two given temp. divided by the difference in the temp. producing it.
R	Rated Resistance Resistance value for which the resistor has been designed, and which is generally used for denomination of the resistor.

Specifications

Series	Rated Power (W)	Resistance Range (Ω)	Tolerance (%)	Operating Temp. Range (°C)	Agency Approvals			Environmental Status	
					 cURus	 CQC	 VDE	RoHS	REACH
RXF21SC	2	3 ~ 68 0.27 ~ 1,000	± 5, ± 10	- 55 ~ 155	• •	• N/A	• •	• •	• •

Note:

1. Non-inductive resistor can be customized as required.
2. Resistance Selection Table (According to IEC60063-2015, blue font is SETsafe | SETfuse common resistance).

Rated Resistance (Ω)	Code	Rated Resistance (Ω)	Code	Rated Resistance (Ω)	Code	Rated Resistance (Ω)	Code
0.10	R10	1.0	1R0	10	10R	100	100R
0.11	R11	1.1	1R1	11	11R	110	110R
0.12	R12	1.2	1R2	12	12R	120	120R
0.13	R13	1.3	1R3	13	13R	130	130R
0.15	R15	1.5	1R5	15	15R	150	150R
0.16	R16	1.6	1R6	16	16R	160	160R
0.18	R18	1.8	1R8	18	18R	180	180R
0.20	R20	2.0	2R0	20	20R	200	200R
0.22	R22	2.2	2R2	22	22R	220	220R
0.24	R24	2.4	2R4	24	24R	240	240R
0.27	R27	2.7	2R7	27	27R	270	270R
0.30	R30	3.0	3R0	30	30R	300	300R
0.33	R33	3.3	3R3	33	33R	330	330R
0.36	R36	3.6	3R6	36	36R	360	360R
0.39	R39	3.9	3R9	39	39R	390	390R
0.43	R43	4.3	4R3	43	43R	430	430R
0.47	R47	4.7	4R7	47	47R	470	470R
0.51	R51	5.1	5R1	51	51R	510	510R
0.56	R56	5.6	5R6	56	56R	560	560R
0.62	R62	6.2	6R2	62	62R	620	620R
0.68	R68	6.8	6R8	68	68R	680	680R
0.75	R75	7.5	7R5	75	75R	750	750R
0.82	R82	8.2	8R2	82	82R	820	820R
0.91	R91	9.1	9R1	91	91R	910	910R

Marking

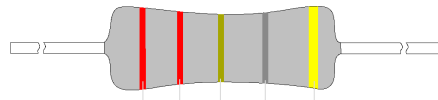

Color	The First Number	The Second Number	Multiple	Tolerance	Power (W)
Black	0	0	10^0	—	—
Brown	1	1	10^1	—	—
Red	2	2	10^2	—	—
Orange	3	3	10^3	—	—
Yellow	4	4	10^4	—	2
Green	5	5	10^5	—	—
Blue	6	6	10^6	—	—
Purple	7	7	10^7	—	—
Grey	8	8	10^8	—	—
White	9	9	10^9	—	1
Gold	—	—	10^{-1}	J: ± 5%	—
Silver	—	—	10^{-2}	K: ± 10%	—

Fusing Time Curve (For Reference Only)

Power & Time curve, showing fusing time at multi-times rated power in the condition of ambient temp. $25\text{ °C} \pm 2\text{ °C}$.

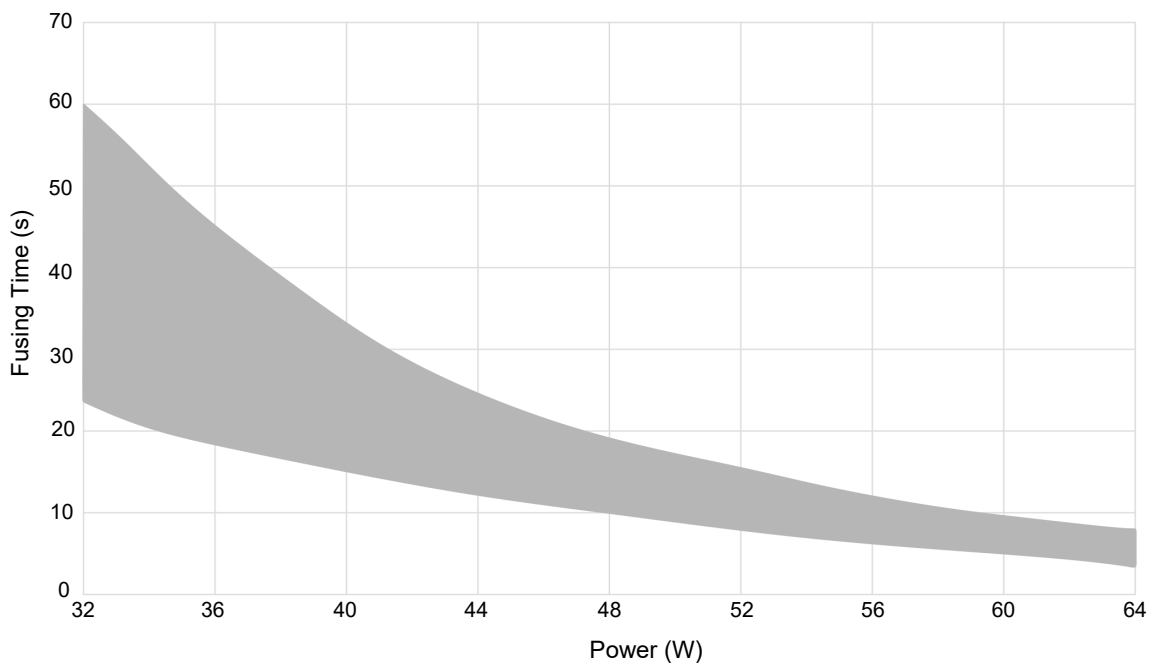

Performance Test

Mechanical Performance Test

Item	Test Condition	Criterion
Tensile Test	A lead withstand 10 N × 60 seconds	No Visible Damage $\Delta R \leq \pm (1\%R + 0.05 \Omega)$
Twist Test	A lead 2 mm away from body, bent 90°, twist 180° × 2 times	No Visible Damage $\Delta R \leq \pm (1\%R + 0.05 \Omega)$

Environmental Test

Item	Test Condition	Criterion
Temp. Cycle	1. - 55 °C × 30 minutes 2. Room Temp. × (10 to 15) minutes 3. 85 °C × 30 minutes 4. Room Temp. × (10 to 15) minutes 5. 5 Cycles from Step 1 to Step 4	$\Delta R \leq \pm (2\%R + 0.05 \Omega)$
Endurance at 25 °C	Rated Voltage 1.5 hours ON, 0.5 hour OFF at 25 °C ± 2 °C, total for 1000 hours.	Legible Marking, No Visible Damage $\Delta R \leq \pm (5\%R + 0.1 \Omega)$

Electrical Performance Test

Item	Test Condition	Criterion
TCR	$TCR = \frac{(R_2 - R_1)}{R_1 (T_2 - T_1)} \times 10^6$ R ₁ : Resistance Value at 25 °C R ₂ : Resistance Value at 125 °C T ₁ : 25 °C, T ₂ : 125 °C	Within Specified Value
Short-Time Overload	2.5U _r × 5 seconds	No Visible Damage $\Delta R \leq \pm (2\%R + 0.05 \Omega)$
Insulation Resistance	Foil Method: Apply 500 VDC between both terminations of the resistor connected together as one pole and the metal foil as the other pole.	Insulation Resistance ≥ 1,000 MΩ
Voltage Proof	Foil Method: Apply 350 VAC × 1 min between terminations and the metal foil.	No Breakdown or Flashover
Fusing Test	Apply test current to the resistor (constant current source)	Fusing Time ≤ 60 seconds
Solderability	Solder Bath (non-activated flux) Scaling Powder: 25% Rosin Alcohol Bath Temp.: 255 °C ± 5 °C Depth of Immersion (From the seating plane or component body): 1.5 mm to 2.0 mm Time of Immersion: (2.5 ± 0.5) seconds	Soldering Area ≥ 95%
Surge Test	Combination Wave Generator (1.2/50 μs, 8/20 μs, 2 Ω), apply open-circuit voltage 1.0 kV (R ≤ 10 Ω) or 2.0 kV (R > 10 Ω) to the resistor, 10 pulses test at 1 minute Interval.	Resistor shall not open after the test

Packaging Information

- Taping

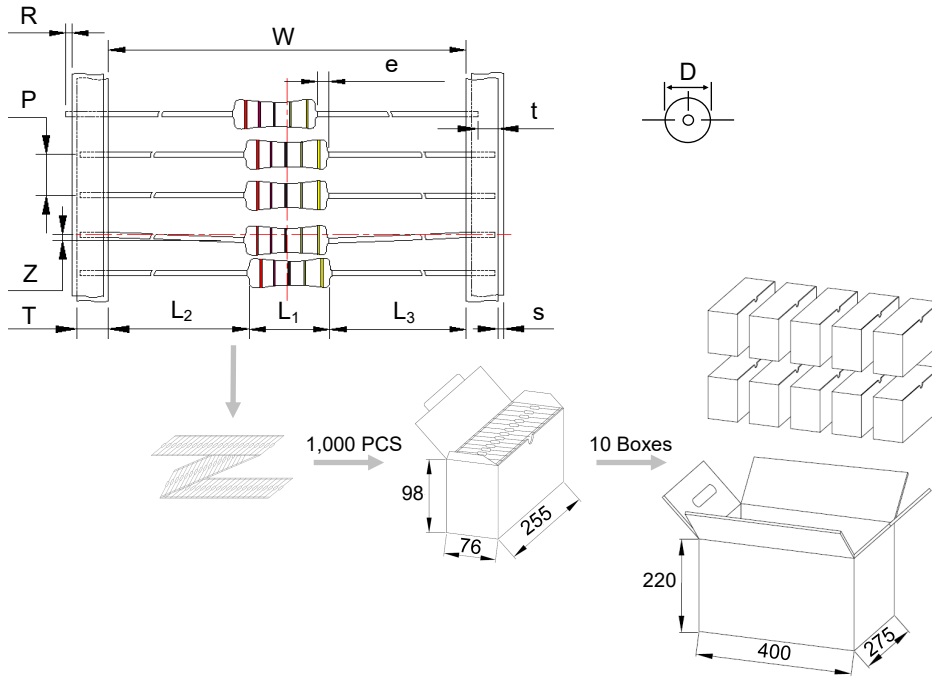

Symbol	Dimensions (mm)
L ₁	11.0 ± 1.0
W	52 ± 2
D	4.5 ± 0.5
P	5.0 ± 0.5
L ₂ - L ₃	1.0 Max.
T	6.0 ± 0.5
Z	1.2 Max.
R	1.0 Max.
t	4.0 Max.
e	0.8 Max.
s	0.8 Max.

Item	Box	Carton
Dimensions (mm)	255 × 76 × 98	400 × 275 × 220
Quantity (PCS)	1,000	10,000
Gross Weight (kg)		8.2 × (1 ± 10%)

Packaging Information

- Taping

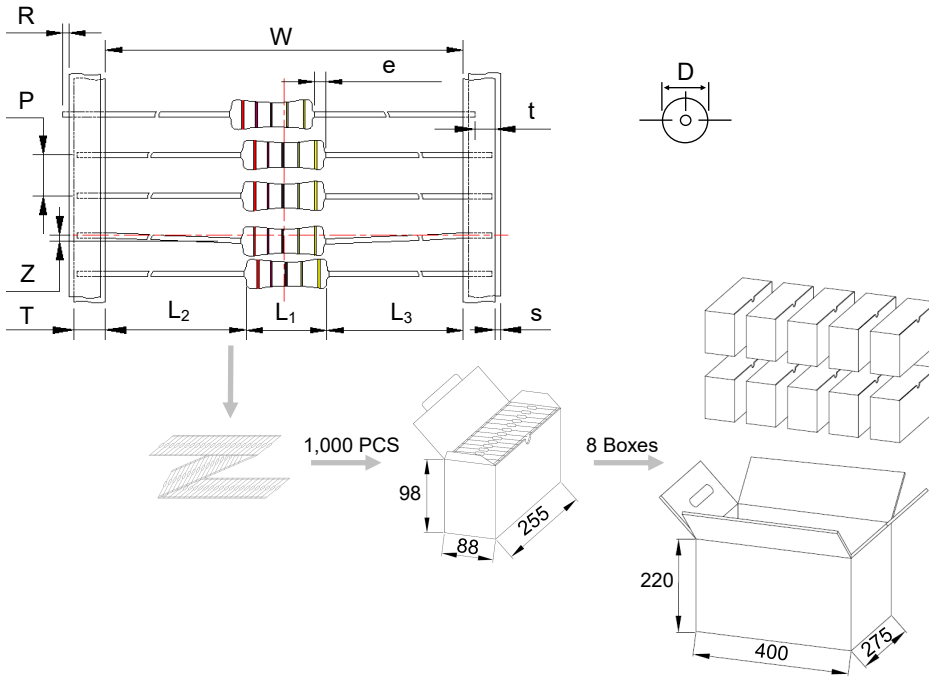

Symbol	Dimensions (mm)
L ₁	11.0 ± 1.0
W	63 ± 2
D	4.5 ± 0.5
P	5.0 ± 0.5
L ₂ - L ₃	1.0 Max.
T	6.0 ± 0.5
Z	1.2 Max.
R	1.0 Max.
t	4.0 Max.
e	0.8 Max.
s	0.8 Max.

Item	Box	Carton
Dimensions (mm)	255 × 76 × 98	400 × 275 × 220
Quantity (PCS)	1,000	8,000
Gross Weight (kg)		7.2 × (1 ± 10%)



ATTENTION

Cold Resistance Test

1. If product TCR is not less than $350 (10^{-6}/^{\circ}\text{C})$, the measured resistance value shall be corrected as the relative resistance value under 25°C according to TCR formula.
2. Resistance Measurement (4-terminal test).

Replacement

As RXF is a non-resettable product, for safety sake, please use the same type of RXF for replacement.

Usage

1. Do not touch the resistor body or pins directly when power is on, to avoid burn or electric shock.
2. When air pressure is from 80 kPa to 106 kPa, the relative altitude shall be +2000 m to - 500 m.

Storage

1. Please store RXF with ambient temp. $10^{\circ}\text{C} \sim 30^{\circ}\text{C}$ and relative humidity 30% ~ 75%.
2. Do not store the RXF at the high temp., high humidity or corrosive gas environment, avoid influencing the solderability of the pins, please use them up within 1 year after receiving the goods.