

FRHV Series



Application

Telecommunication and Data transmitting

Product Features

Low hold current, Solid state



Operation Current

0.08 A~0.40A

Maximum Operating Voltage

60V/100V/250V_{DC}

Maximum Interrupt Voltage

250V/600V_{AC}



Temperature Range

-40°C to 85°C

Agency Recognition

AGENCY	AGENCY FILE NUMBER
	UL(E211981)
	C-UL(E211981)
	TÜV (R50138901)



SVHC Compliant

Electrical Characteristics (23°C)

Part Number	Hold Current I _H , A	Trip Current I _T , A	Max. Time to trip		Max. Current I _{MAX} , A	Max. Oper. Voltage V _{MAX} , V _{DC}	Max. Int. Voltage V _{I-MAX} , V _{AC}	Typ. Power Pd, W	Resistance	
			Current A	Time Sec					R _{MIN}	R _{1MAX}
FRH080-250VF	0.08	0.16	0.35	4.0	3.0	100	250	1.0	14.00	33.00
FRH110-250VF	0.11	0.22	1.00	2.0	3.0	100	250	1.0	5.00	16.00
FRH120-250VF	0.12	0.24	1.00	2.0	3.0	100	250	1.0	4.00	16.00
FRH145-250VF	0.15	0.29	1.00	2.5	3.0	100	250	1.0	3.00	12.00
FRH180-250XF	0.18	0.65	3.00	2.0	10.0	100	250	1.0	0.80	4.00
FRH150-600MF	0.15	0.30	1.00	4.0	3.0	250	600	1.0	6.00	17.00
FRH160-600MF	0.16	0.32	1.00	7.0	3.0	250	600	1.0	4.00	16.00
FRH160-600VF	0.16	0.32	1.00	7.0	3.0	250	600	1.0	4.00	18.00
FRH200-600VF	0.20	0.40	1.00	12.0	3.0	250	600	1.0	4.00	13.50
FRH250-600VF	0.25	0.85	3.00	1.0	3.0	250	600	1.0	1.00	7.00
FRH400-600F	0.40	1.00	3.00	4.0	3.0	60	600	1.0	0.95	1.90

Thermal Derating for PPTC Device at Various Ambient Temperatures

TEMPERATURE	-40°C	-20°C	0°C	23°C	30°C	40°C	50°C	60°C	70°C	85°C
DERATING %	158%	138%	119%	100%	92%	83%	73%	64%	54%	40%

Typical Time-To-Trip at 23°C

- A = FRH080-250VF
- B = FRH110-250VF
- C = FRH120-250VF
- D = FRH145-250VF
- E = FRH180-250XF

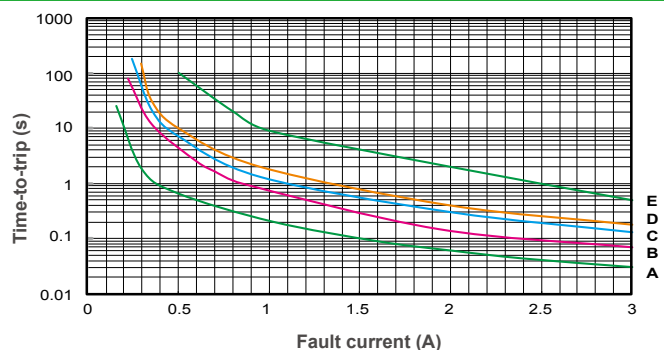

NOTE : All Specifications subject to change without notice.

IV - Radial Leaded PPTC

Typical Time-To-Trip at 23°C

- F = FRH150-600MF
- G = FRH160-600MF
- H = FRH160-600VF
- I = FRH200-600VF
- J = FRH250-600VF
- K = FRH400-600F

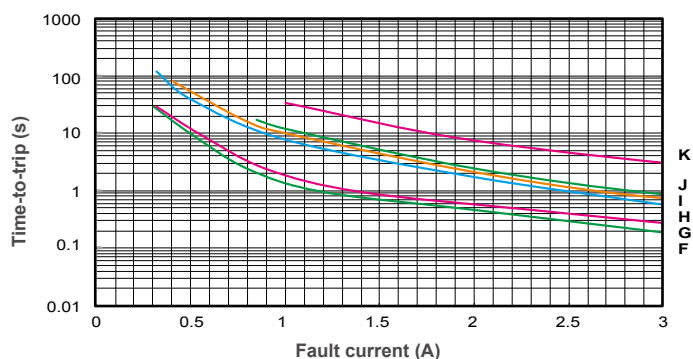

FRHV Product Dimensions (mm)

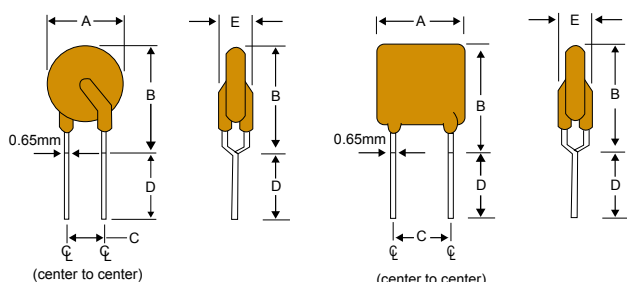
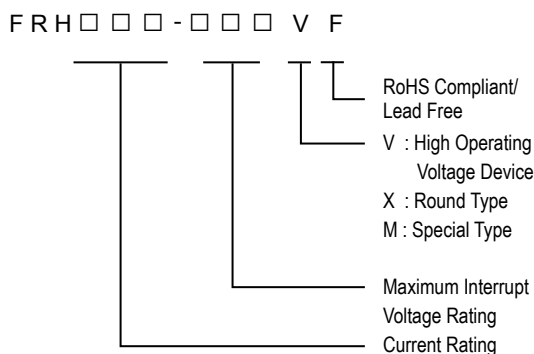

Fig.1
Lead Size : 22AWG
Φ 0.65 mm Diameter

Fig.2
Lead Size : 22AWG
Φ 0.65 mm Diameter

Part Number	Fig.	A	B	C	D	E
		Max.	Max.	Typ.	Min.	Max.
FRH080-250VF	1	5.8	9.6	5.0	4.7	4.6
FRH110-250VF	1	6.8	9.9	5.0	4.7	4.6
FRH120-250VF	2	6.5	11.0	5.0	4.7	4.6
FRH145-250VF	2	6.5	11.0	5.0	4.7	4.6
FRH180-250XF	1	9.0	12.0	5.0	4.7	3.8
FRH150-600MF	2	9.0	12.5	5.0	4.7	4.6
FRH160-600MF	2	9.0	12.5	5.0	4.7	4.6
FRH160-600VF	2	16.0	12.6	5.0	4.7	6.0
FRH200-600VF	2	12.0	14.0	5.0	4.7	6.0
FRH250-600VF	2	12.0	15.0	5.0	4.7	6.0
FRH400-600F	2	15.0	14.5	5.0	4.7	6.0

Part Numbering System



Part Marking System

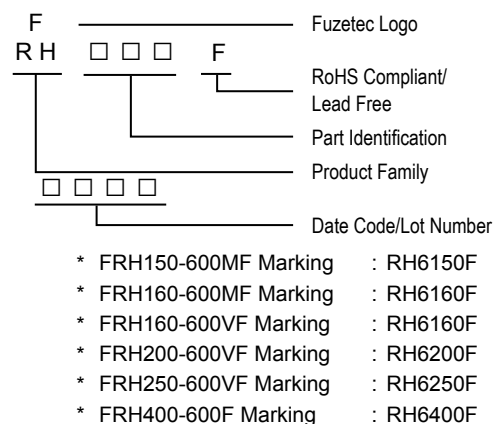

Package Information

Part Number	Standard Package
FRH080-250VF~FRH145-250VF	: 300 Pcs/Bag, 1.5K Reel/Tape
FRH180-250XF	: 200 Pcs/Bag, 1.5K Reel/Tape
FRH150-600MF~FRH160-600MF	: 100 Pcs/Bag, 1.2K Reel/Tape
FRH160-600VF	: 100 Pcs/Bag, 0.6K Reel/Tape
FRH200-600VF~FRH400-600F	: 100 Pcs/Bag

Physical specifications

Lead material	Tin plated copper, 22 AWG.
Soldering characteristics	MIL-STD-202, Method 208E.
Insulating coating	Flame retardant epoxy, meets UL-94V-0 requirement.
*NOTE : All FRHV products are designed to assist equipment to pass ITU K20/K21 UL60950 or GR1089 specification.	
*FRH150-600MF, FRH160-600VF meet UL497A Overvoltage and Endurance Conditioning requirements for Thermistor type component.	

Warning :



- Each product should be carefully evaluated and tested for their suitability of application.
- Operation beyond the specified maximum ratings or improper use may result in damage and possible electrical arcing and/or flame.
- PPTC device are intended for occasional overcurrent protection. Application for repeated overcurrent condition and/or prolonged trip are not anticipated.
- Avoid contact of PPTC device with chemical solvent, including some inert material such as silicone based oil, lubricant and etc. Prolonged contact will damage the device performance.
- Additional protection mechanism are strongly recommended to be used in conjunction with the PPTC device for protection against abnormal or failure conditions.
- Avoid use of PPTC device in a constrained space such as potting material, housing and containers where have limited space to accommodate device thermal expansion and/or contraction.

NOTE : All Specifications subject to change without notice.